

MEASUREMENT REPORT

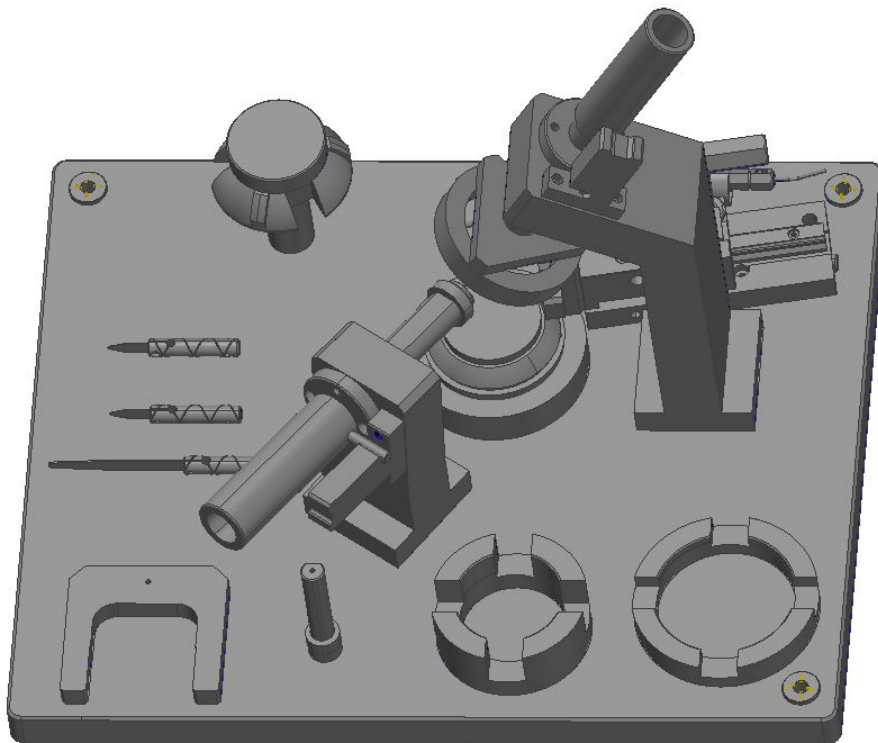

Customer: MAGOVE
Operator: Felipe Martinez
E-mail: felipe.martinez@mess.com.mx
Workspace: PROGRAMA FSJ063
Project: Inspector Project - piece 1

Part name: FSJ063
Part number: 4882543-B
Drawing : S/R
Device: MESS-BRAA-004



G BUJE 3				
	Nom	Meas	Dev	Test
X	1821,142	1821,158	0,016	○
Y	29,864	29,910	0,046	○
Z	670,787	670,819	0,032	○

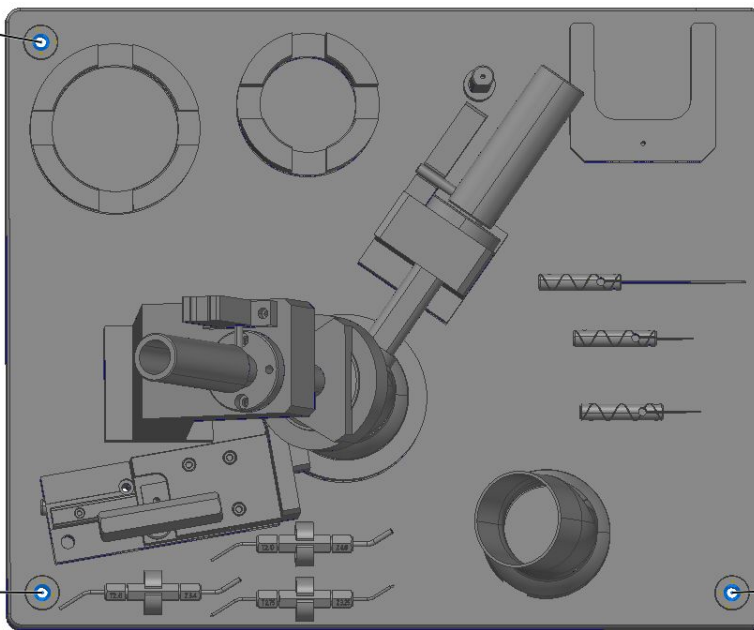

G BUJE 1				
	Nom	Meas	Dev	Test
X	1791,964	1791,960	-0,004	○
Y	424,054	424,048	-0,006	○
Z	609,442	609,436	-0,006	○

G BUJE 2				
	Nom	Meas	Dev	Test
X	2015,347	2015,333	-0,014	○
Y	508,938	508,897	-0,041	○
Z	1048,640	1048,613	-0,027	○



ALIENACION 3D (BEST FIT)

Length Units Millimeters

BUJE 1

Control	Nom	Meas	Tol	Dev	Test
X	1791,964	1791,960	±0,100	-0,004	Pass
Y	424,054	424,048	±0,100	-0,006	Pass
Z	609,442	609,436	±0,100	-0,006	Pass

BUJE 2

Control	Nom	Meas	Tol	Dev	Test
X	2015,347	2015,333	±0,100	-0,014	Pass
Y	508,938	508,897	±0,100	-0,041	Pass
Z	1048,640	1048,613	±0,100	-0,027	Pass

BUJE 3

Control	Nom	Meas	Tol	Dev	Test
X	1821,142	1821,158	±0,100	0,016	Pass
Y	29,864	29,910	±0,100	0,046	Pass
Z	670,787	670,819	±0,100	0,032	Pass

Customer: MAGOVE
Operator: Felipe Martinez
E-mail: felipe.martinez@mess.com.mx

Part name: FSJ063
Part number: 4882543-B
Piece: piece 1



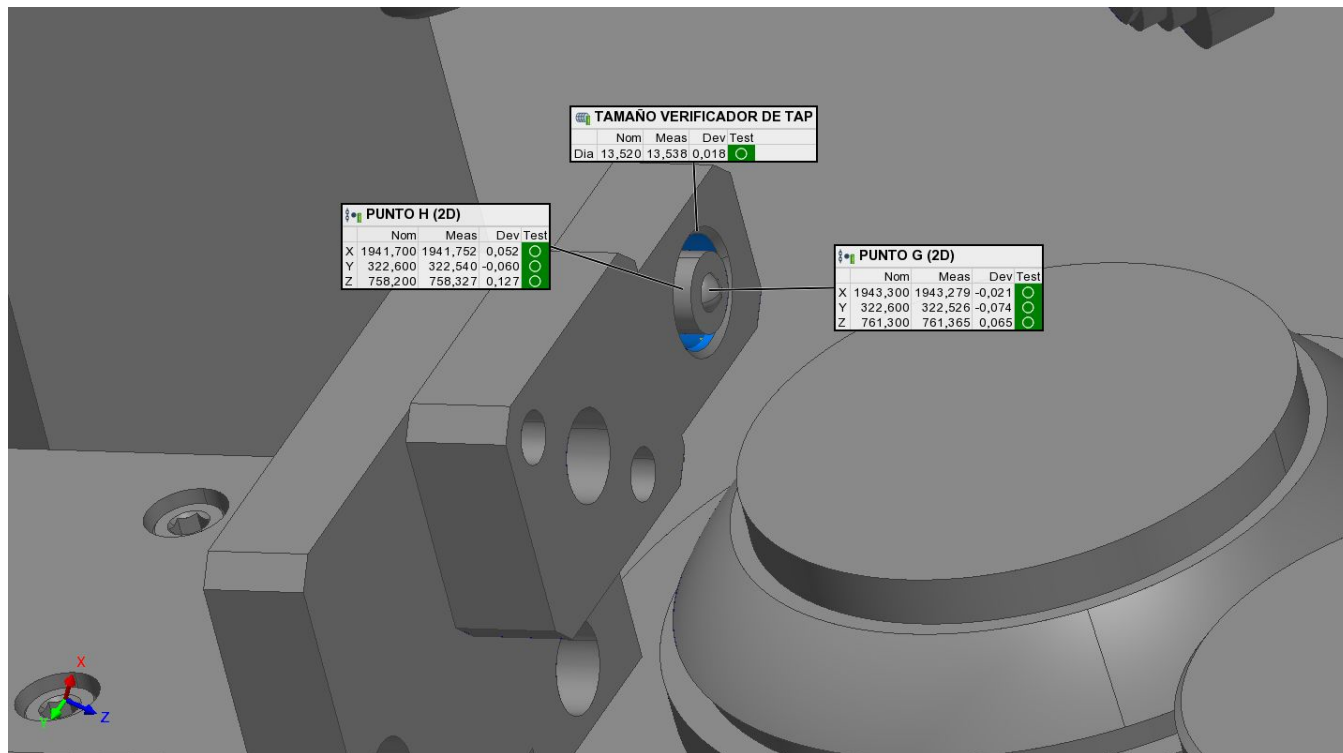

Feature Table

Length Units Millimeters

TAMAÑO VERIFICADOR DE TAP

Control	Nom	Meas	Tol	Dev	Test
Diameter	13,520	13,538	±0,050	0,018	Pass

• PUNTO H (2D)

Control	Nom	Meas	Tol	Dev	Test
X	1941,700	1941,752	±0,150	0,052	Pass
Y	322,600	322,540	±0,150	-0,060	Pass
Z	758,200	758,327	±0,150	0,127	Pass

• PUNTO G (2D)

Control	Nom	Meas	Tol	Dev	Test
X	1943,300	1943,279	±0,150	-0,021	Pass
Y	322,600	322,526	±0,150	-0,074	Pass
Z	761,300	761,365	±0,150	0,065	Pass

Customer: MAGOVE
Operator: Felipe Martinez
E-mail: felipe.martinez@mess.com.mx

Part name: FSJ063
Part number: 4882543-B
Piece: piece 1

