

MEASUREMENT REPORT

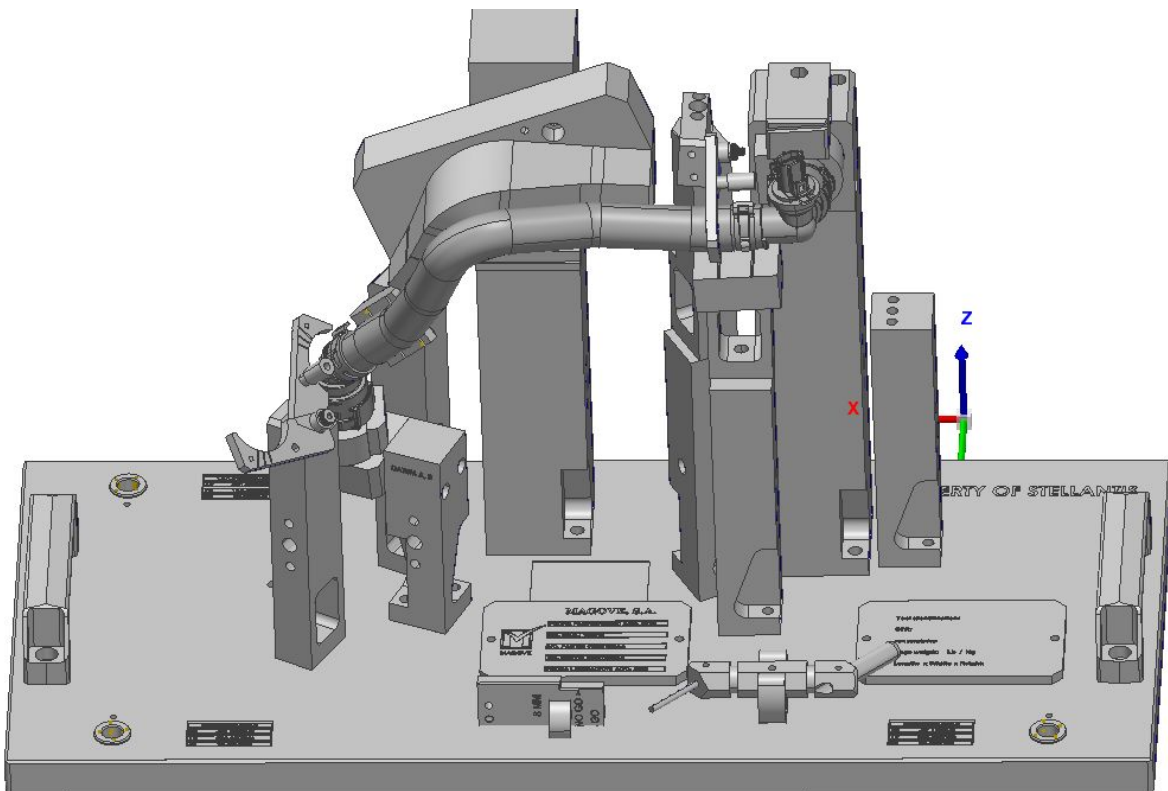

Customer: MAGOVE
Operator: Felipe Martinez
E-mail: felipe.martinez@mess.com.mx
Workspace: PROGRAMA TRI013
Project: PROGRAMA TRI013 - piece 1

Part name: TRI013
Part number: 68597288AA
Drawing : S/R
Device: MESS-BRAA-004



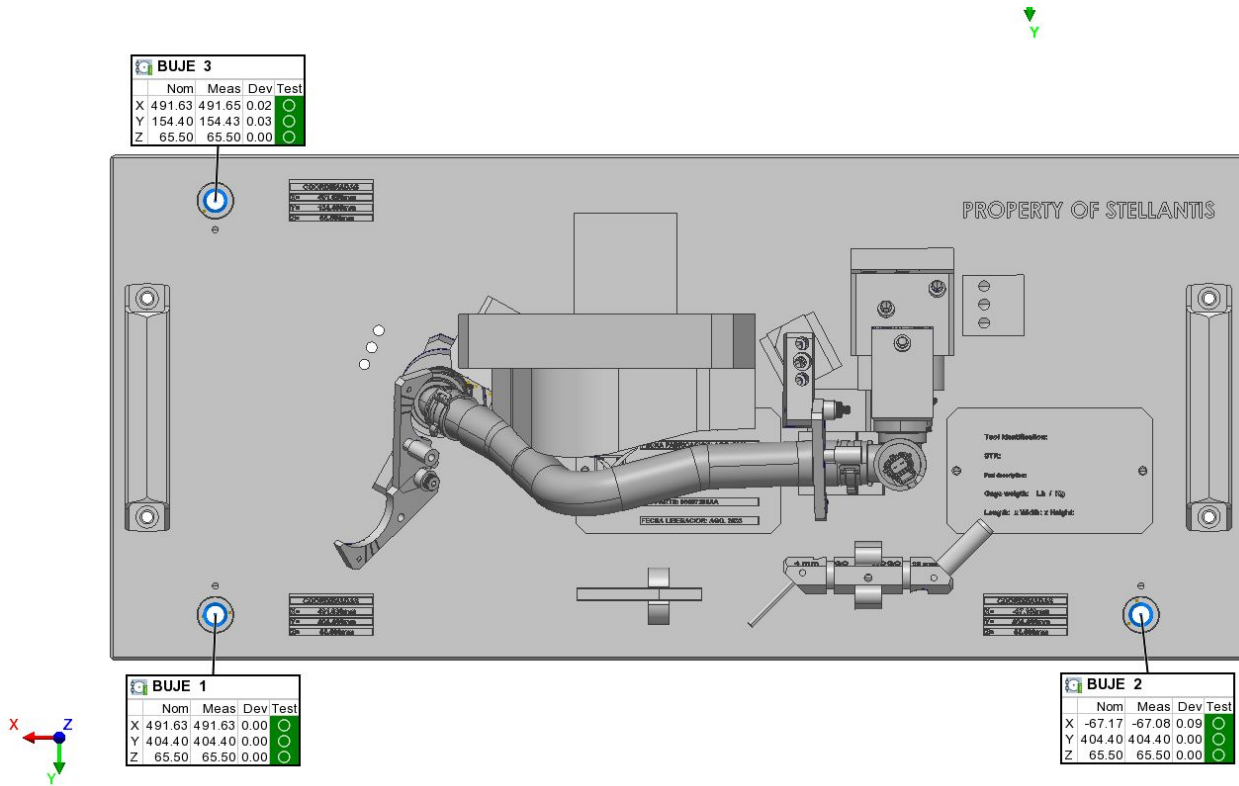

Feature Table

Length Units Millimeters

BUJE 1

Control	Nom	Meas	Tol	Dev	Test
X	491.63	491.63	±0.10	0.00	Pass
Y	404.40	404.40	±0.10	0.00	Pass
Z	65.50	65.50	±0.10	0.00	Pass

BUJE 2

Control	Nom	Meas	Tol	Dev	Test
X	-67.17	-67.08	±0.10	0.09	Pass
Y	404.40	404.40	±0.10	0.00	Pass
Z	65.50	65.50	±0.10	0.00	Pass

BUJE 3

Control	Nom	Meas	Tol	Dev	Test
X	491.63	491.65	±0.10	0.02	Pass
Y	154.40	154.43	±0.10	0.03	Pass
Z	65.50	65.50	±0.10	0.00	Pass

Customer: MAGOVE
Operator: Felipe Martinez
E-mail: felipe.martinez@mess.com.mx

Part name: TRI013
Part number: 68597288AA
Piece: piece 1



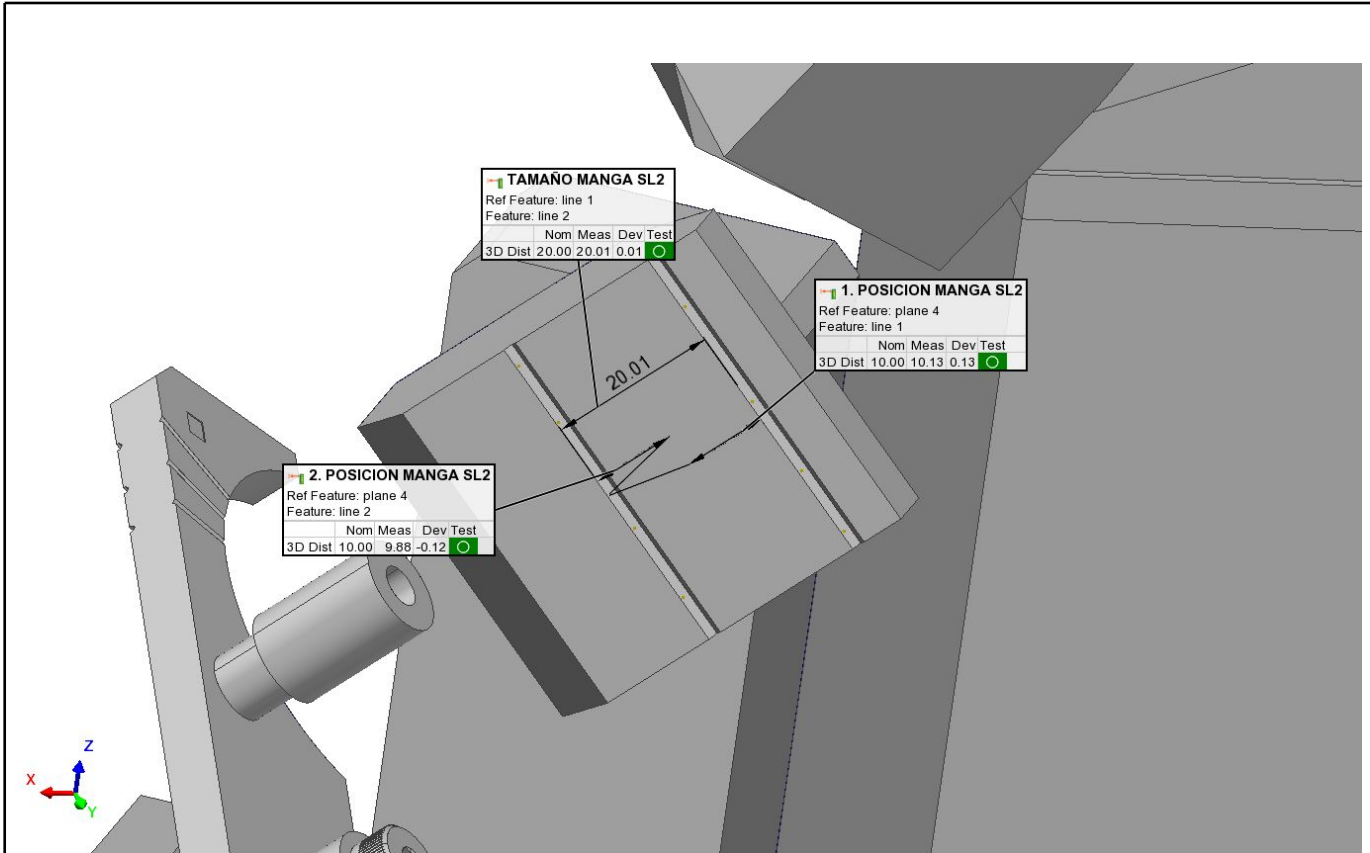

Feature Table

Length Units Millimeters

↔ 1. POSICION MANGA SL2						Feature: line 1, Ref Feature: plane 4
Control	Nom	Meas	Tol	Dev	Test	
3D Distance	10.00	10.13	±0.20	0.13	Pass	
↔ 2. POSICION MANGA SL2						Feature: line 2, Ref Feature: plane 4
Control	Nom	Meas	Tol	Dev	Test	
3D Distance	10.00	9.88	±0.20	-0.12	Pass	
↔ TAMAÑO MANGA SL2						Feature: line 2, Ref Feature: line 1
Control	Nom	Meas	Tol	Dev	Test	
3D Distance	20.00	20.01	±0.12	0.01	Pass	

Customer: MAGOVE
Operator: Felipe Martinez
E-mail: felipe.martinez@mess.com.mx

Part name: TRI013
Part number: 68597288AA
Piece: piece 1

