

MEASUREMENT REPORT

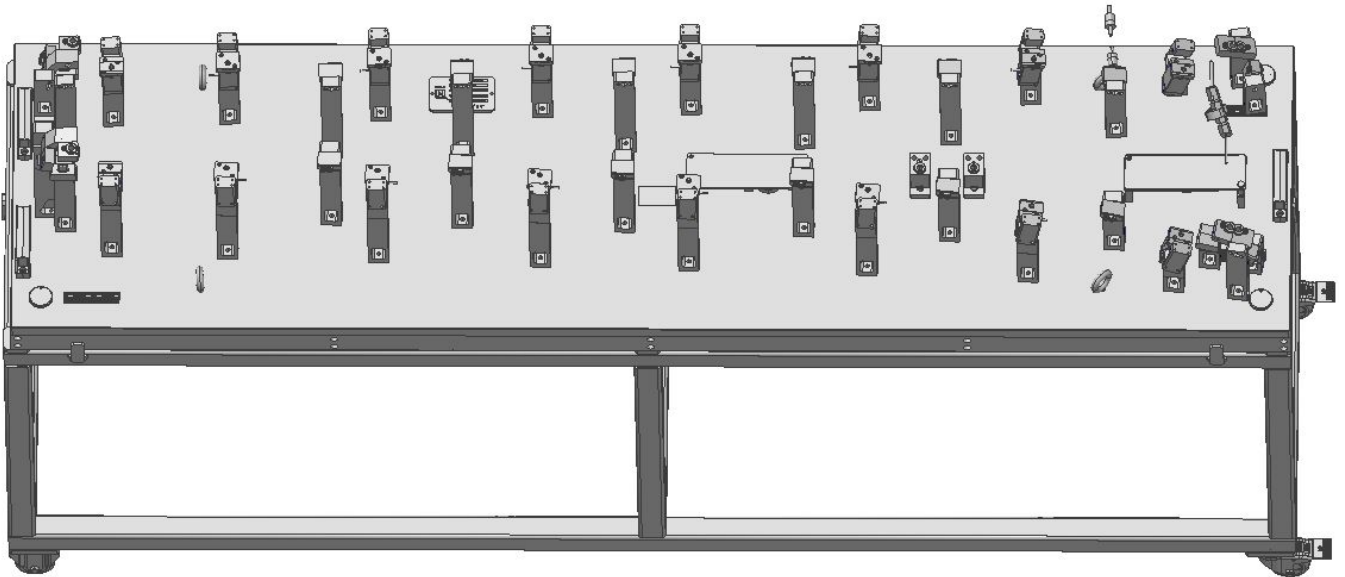

Customer: MAGOVE

Operator: Felipe Martinez

E-mail: felipe.martinez@mess.com.mx

Workspace: REH007 PROGRAMA

Project: REH007_68228296_68228502 -
piece 1

Part name: CC807-RH

Part number: 68228296/68228502

Drawing : S/R

Device: MESS-BRAA-003



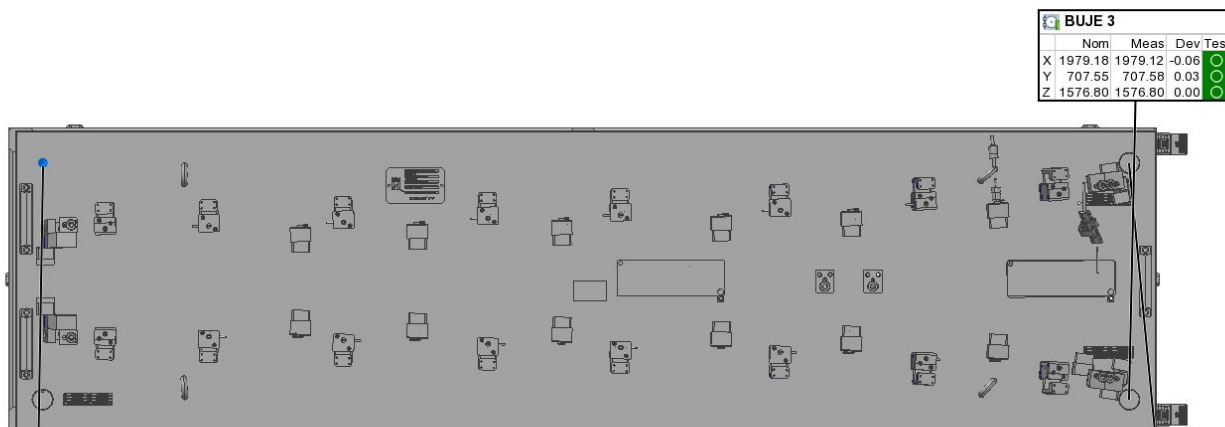

	Nom	Meas	Dev	Test
X	4278.75	4278.68	-0.07	Pass
Y	207.55	207.55	0.00	Pass
Z	1576.80	1576.80	0.00	Pass

	Nom	Meas	Dev	Test
X	1979.18	1979.12	-0.06	Pass
Y	707.55	707.58	0.03	Pass
Z	1576.80	1576.80	0.00	Pass

	Nom	Meas	Dev	Test
X	1979.18	1979.18	0.00	Pass
Y	207.55	207.55	0.00	Pass
Z	1576.80	1576.80	0.00	Pass



Feature Table

Length Units Millimeters

BUJE 1

Control	Nom	Meas	Tol	Dev	Test
X	1979.18	1979.18	±0.10	0.00	Pass
Y	207.55	207.55	±0.10	0.00	Pass
Z	1576.80	1576.80	±0.10	0.00	Pass

BUJE 2

Control	Nom	Meas	Tol	Dev	Test
X	4278.75	4278.68	±0.10	-0.07	Pass
Y	207.55	207.55	±0.10	0.00	Pass
Z	1576.80	1576.80	±0.10	0.00	Pass

BUJE 3

Control	Nom	Meas	Tol	Dev	Test
X	1979.18	1979.12	±0.10	-0.06	Pass
Y	707.55	707.58	±0.10	0.03	Pass
Z	1576.80	1576.80	±0.10	0.00	Pass

Customer: MAGOVE
Operator: Felipe Martinez
E-mail: felipe.martinez@mess.com.mx

Part name: CC807-RH
Part number: 68228296/68228502
Piece: piece 1



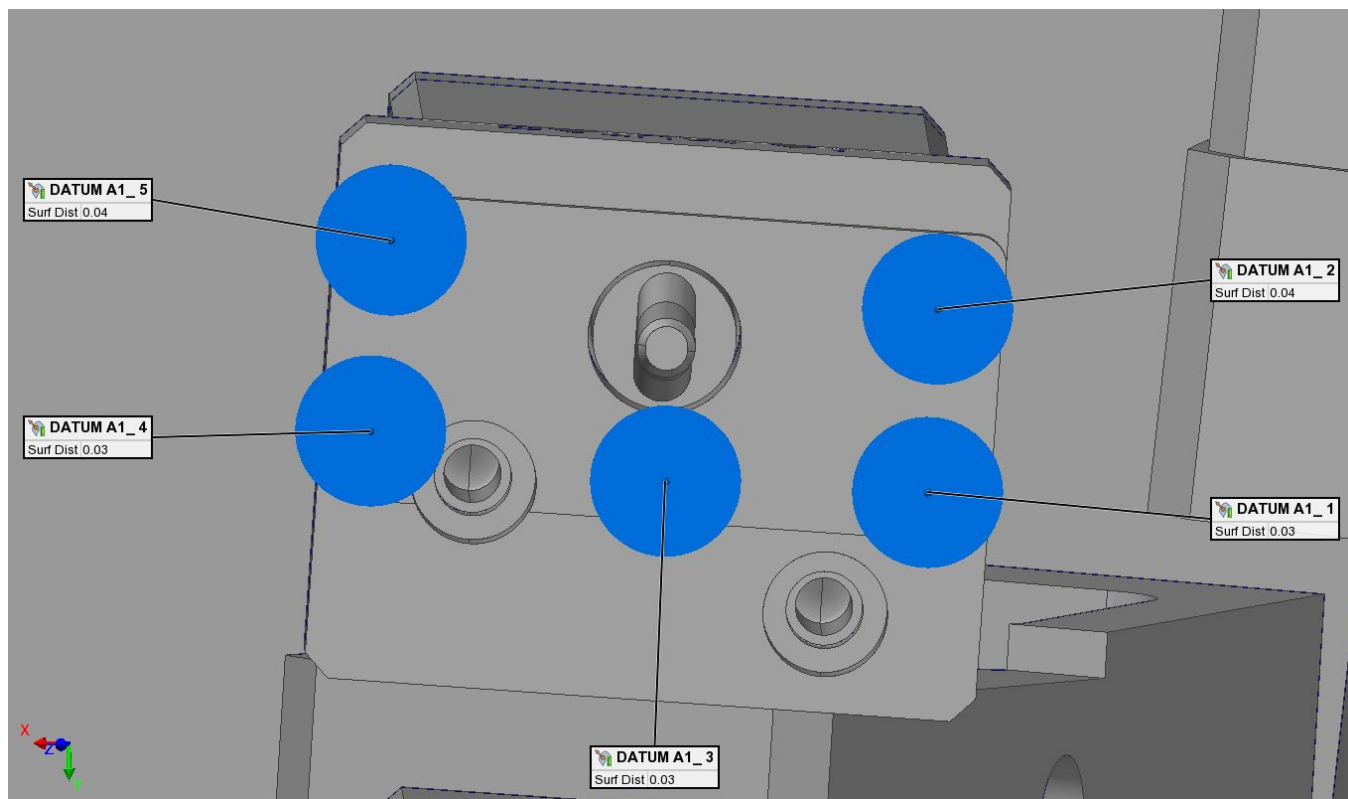

Comparison Point Table

Units Millimeters

DATUM A1_1

Control	Nom	Meas	Tol	Dev	Test
Surface Distance		0.03	±0.05	0.03	Pass

DATUM A1_2

Control	Nom	Meas	Tol	Dev	Test
Surface Distance		0.04	±0.05	0.04	Pass

DATUM A1_3

Control	Nom	Meas	Tol	Dev	Test
Surface Distance		0.03	±0.05	0.03	Pass

DATUM A1_4

Control	Nom	Meas	Tol	Dev	Test
Surface Distance		0.03	±0.05	0.03	Pass

DATUM A1_5

Control	Nom	Meas	Tol	Dev	Test
Surface Distance		0.04	±0.05	0.04	Pass

Customer: MAGOVE
Operator: Felipe Martinez
E-mail: felipe.martinez@mess.com.mx

Part name: CC807-RH
Part number: 68228296/68228502
Piece: piece 1



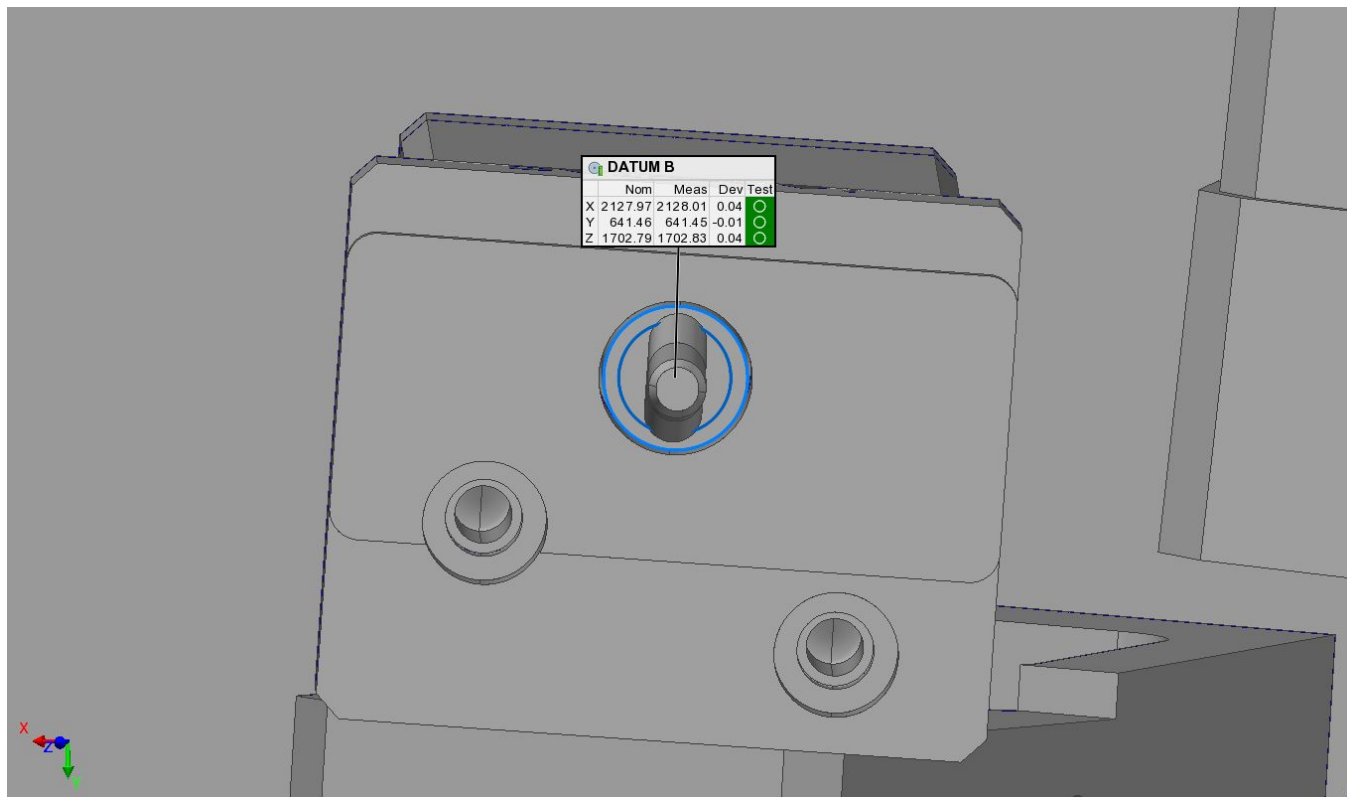

DATUM B

Length Units Millimeters

DATUM B

Control	Nom	Meas	Tol	Dev	Test
X	2127.97	2128.01	±0.05	0.04	Pass
Y	641.46	641.45	±0.05	-0.01	Pass
Z	1702.79	1702.83	±0.05	0.04	Pass

Customer: MAGOVE
 Operator: Felipe Martinez
 E-mail: felipe.martinez@mess.com.mx

Part name: CC807-RH
 Part number: 68228296/68228502
 Piece: piece 1



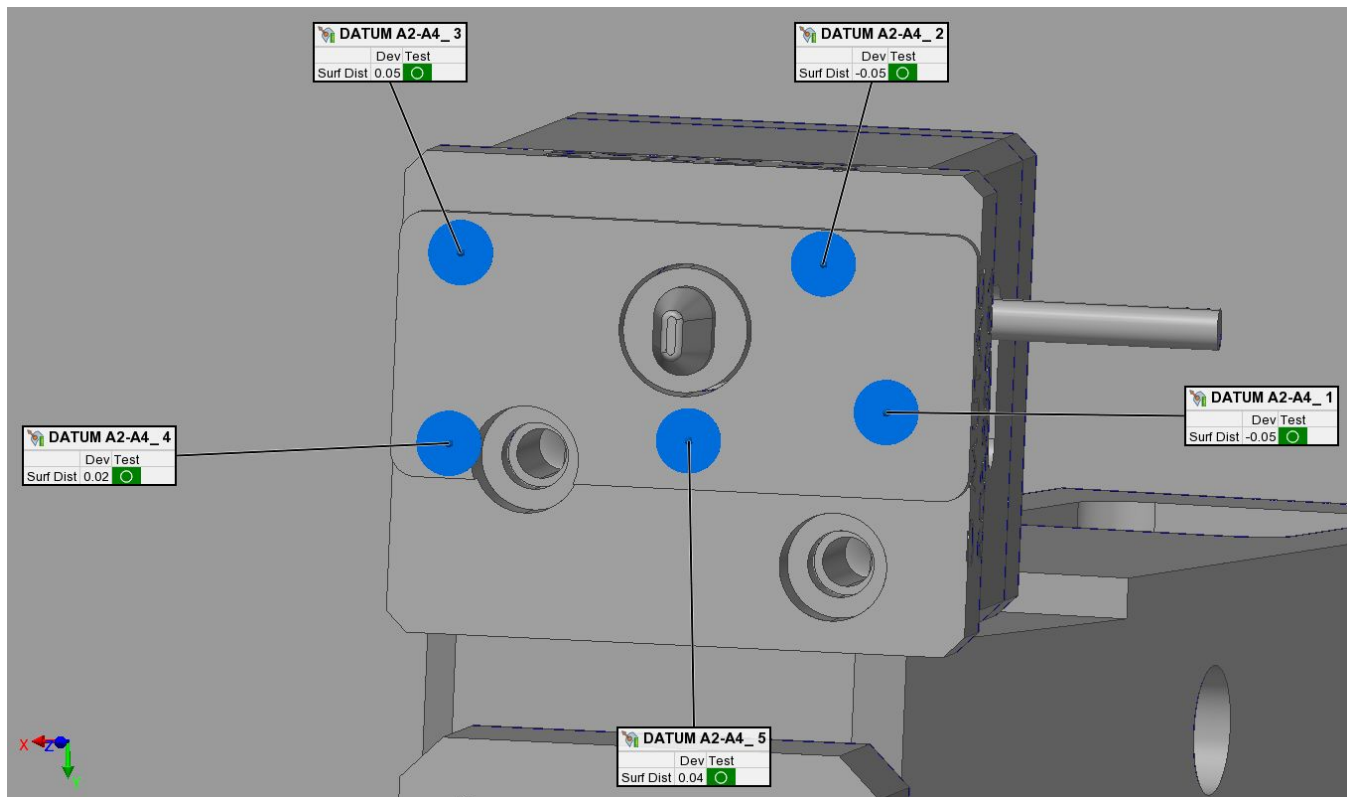

Comparison Point Table

Units Millimeters

DATUM A2-A4_1

Control	Nom	Meas	Tol	Dev	Test
Surface Distance		-0.05	±0.05	-0.05	Pass

DATUM A2-A4_2

Control	Nom	Meas	Tol	Dev	Test
Surface Distance		-0.05	±0.05	-0.05	Pass

DATUM A2-A4_3

Control	Nom	Meas	Tol	Dev	Test
Surface Distance		0.05	±0.05	0.05	Pass

DATUM A2-A4_4

Control	Nom	Meas	Tol	Dev	Test
Surface Distance		0.02	±0.05	0.02	Pass

DATUM A2-A4_5

Control	Nom	Meas	Tol	Dev	Test
Surface Distance		0.04	±0.05	0.04	Pass

Customer: MAGOVE
 Operator: Felipe Martinez
 E-mail: felipe.martinez@mess.com.mx

Part name: CC807-RH
 Part number: 68228296/68228502
 Piece: piece 1



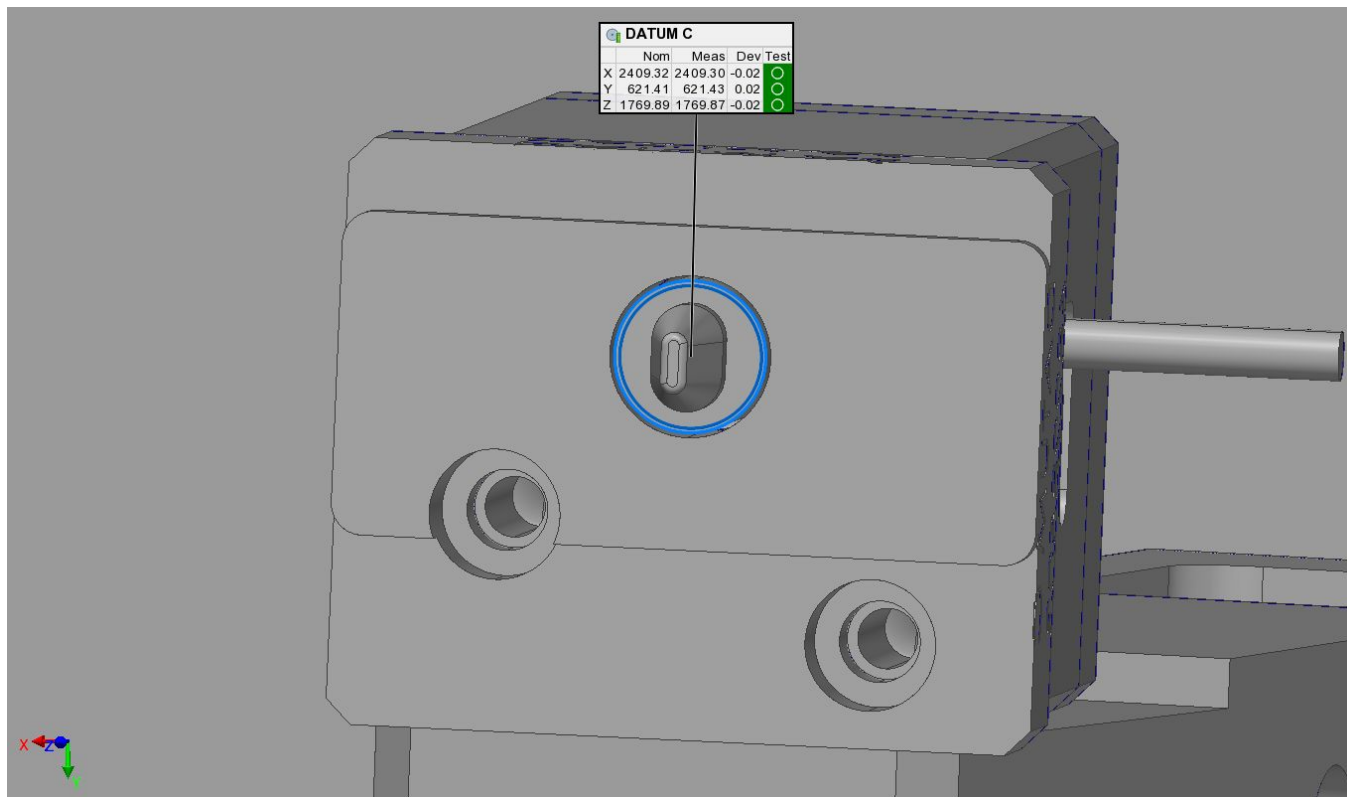

DATUM C

Length Units Millimeters

DATUM C

Control	Nom	Meas	Tol	Dev	Test
X	2409.32	2409.30	±0.05	-0.02	Pass
Y	621.41	621.43	±0.05	0.02	Pass
Z	1769.89	1769.87	±0.05	-0.02	Pass

Customer: MAGOVE
Operator: Felipe Martinez
E-mail: felipe.martinez@mess.com.mx

Part name: CC807-RH
Part number: 68228296/68228502
Piece: piece 1



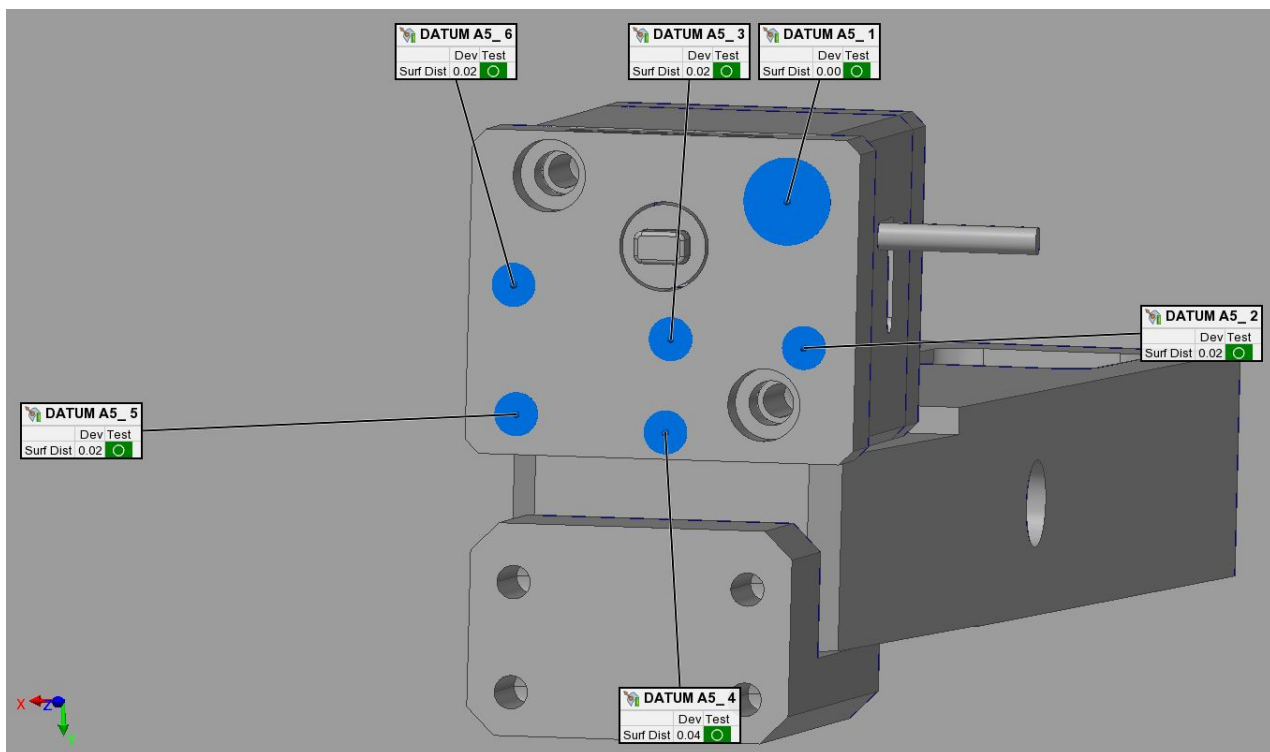

Comparison Point Table

Units Millimeters

DATUM A5_1

Control	Nom	Meas	Tol	Dev	Test
Surface Distance		0.00	±0.05	0.00	Pass

DATUM A5_2

Control	Nom	Meas	Tol	Dev	Test
Surface Distance		0.02	±0.05	0.02	Pass

DATUM A5_3

Control	Nom	Meas	Tol	Dev	Test
Surface Distance		0.02	±0.05	0.02	Pass

DATUM A5_4

Control	Nom	Meas	Tol	Dev	Test
Surface Distance		0.04	±0.05	0.04	Pass

DATUM A5_5

Control	Nom	Meas	Tol	Dev	Test
Surface Distance		0.02	±0.05	0.02	Pass

DATUM A5_6

Control	Nom	Meas	Tol	Dev	Test
Surface Distance		0.02	±0.05	0.02	Pass

Customer: MAGOVE
Operator: Felipe Martinez
E-mail: felipe.martinez@mess.com.mx

Part name: CC807-RH
Part number: 68228296/68228502
Piece: piece 1



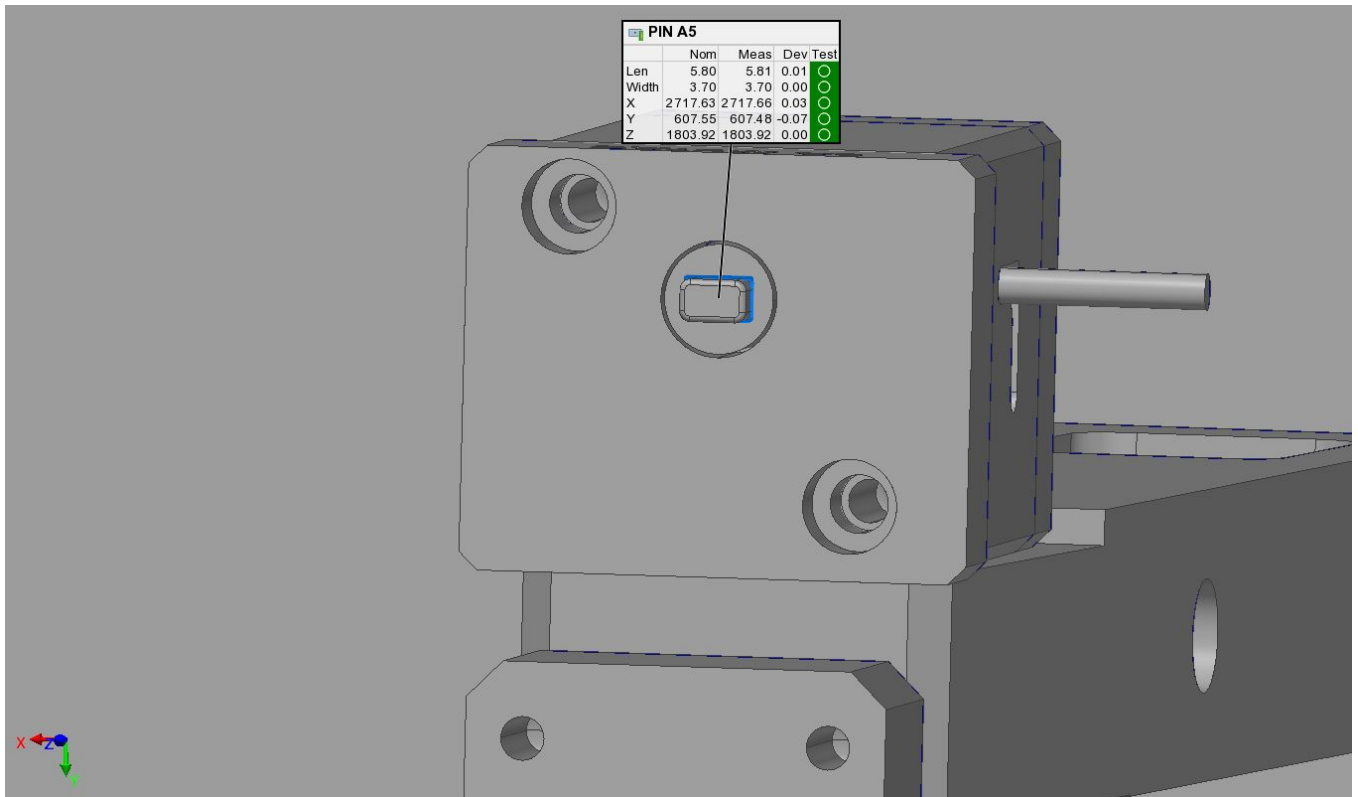

Feature Table

Length Units Millimeters

PIN A5

Control	Nom	Meas	Tol	Dev	Test
Length	5.80	5.81	+0.02/0.00	0.01	Pass
Width	3.70	3.70	+0.02/0.00	0.00	Pass
X	2717.63	2717.66	±0.10	0.03	Pass
Y	607.55	607.48	±0.10	-0.07	Pass
Z	1803.92	1803.92	±0.10	0.00	Pass

Customer: MAGOVE
Operator: Felipe Martinez
E-mail: felipe.martinez@mess.com.mx

Part name: CC807-RH
Part number: 68228296/68228502
Piece: piece 1



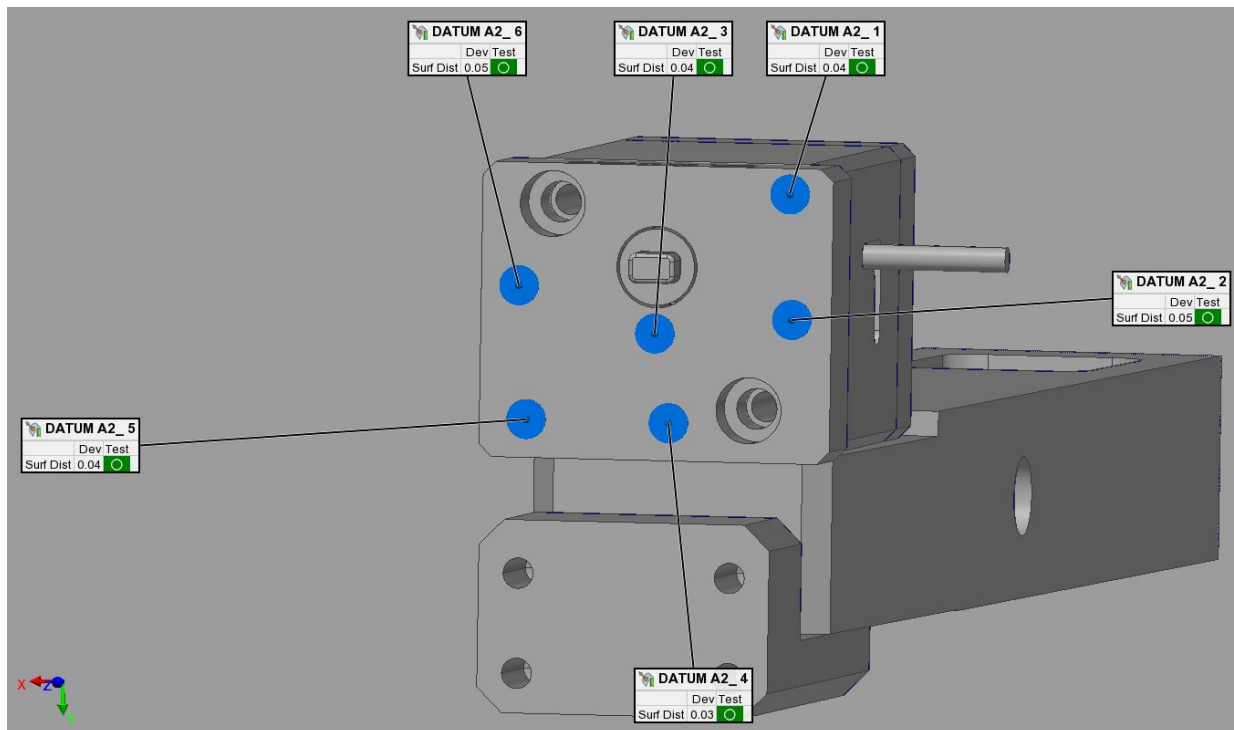

Comparison Point Table

Units Millimeters

DATUM A2_1

Control	Nom	Meas	Tol	Dev	Test
Surface Distance		0.04	±0.05	0.04	Pass

DATUM A2_2

Control	Nom	Meas	Tol	Dev	Test
Surface Distance		0.05	±0.05	0.05	Pass

DATUM A2_3

Control	Nom	Meas	Tol	Dev	Test
Surface Distance		0.04	±0.05	0.04	Pass

DATUM A2_4

Control	Nom	Meas	Tol	Dev	Test
Surface Distance		0.03	±0.05	0.03	Pass

DATUM A2_5

Control	Nom	Meas	Tol	Dev	Test
Surface Distance		0.04	±0.05	0.04	Pass

DATUM A2_6

Control	Nom	Meas	Tol	Dev	Test
Surface Distance		0.05	±0.05	0.05	Pass

Customer: MAGOVE
Operator: Felipe Martinez
E-mail: felipe.martinez@mess.com.mx

Part name: CC807-RH
Part number: 68228296/68228502
Piece: piece 1



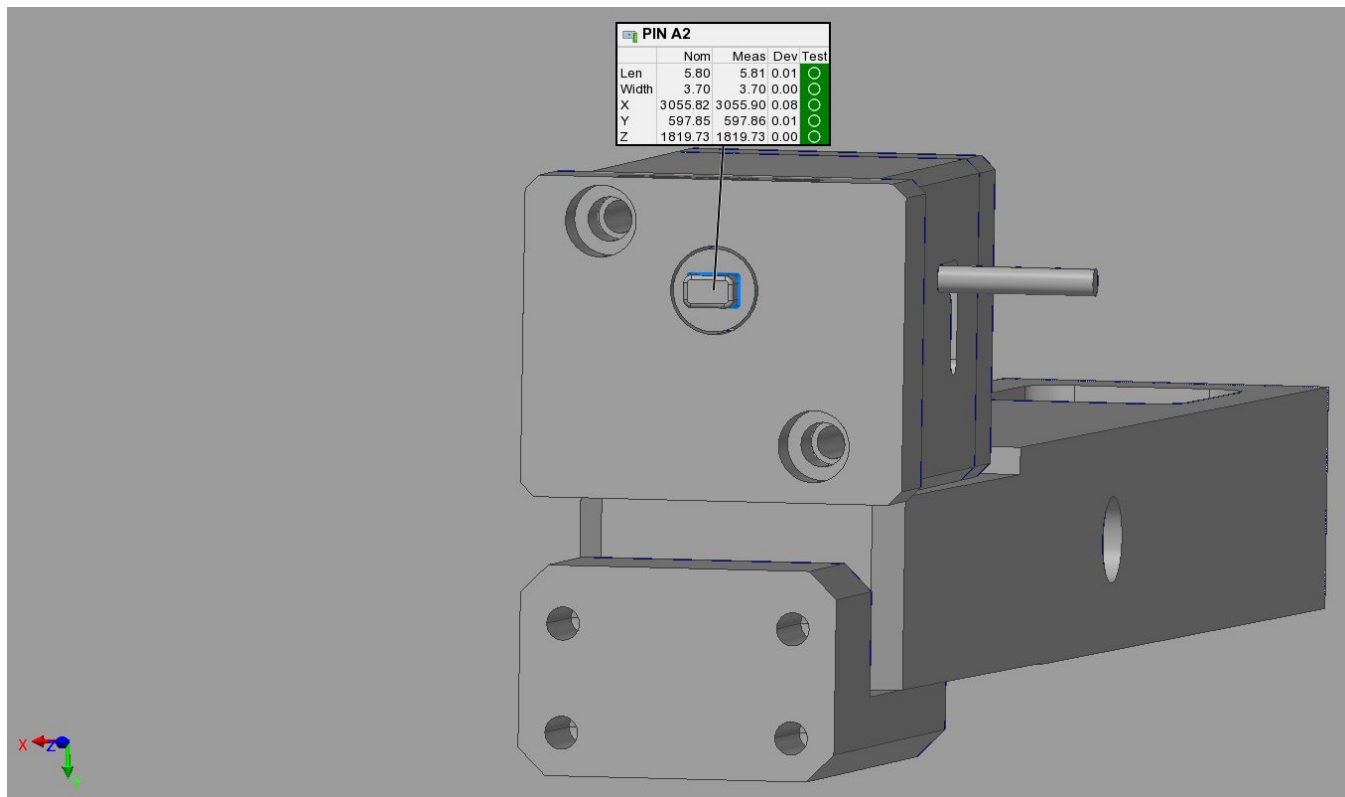

Feature Table

Length Units Millimeters

PIN A2

Control	Nom	Meas	Tol	Dev	Test
Length	5.80	5.81	+0.02/0.00	0.01	Pass
Width	3.70	3.70	+0.02/0.00	0.00	Pass
X	3055.82	3055.90	±0.10	0.08	Pass
Y	597.85	597.86	±0.10	0.01	Pass
Z	1819.73	1819.73	±0.10	0.00	Pass

Customer: MAGOVE
 Operator: Felipe Martinez
 E-mail: felipe.martinez@mess.com.mx

Part name: CC807-RH
 Part number: 68228296/68228502
 Piece: piece 1



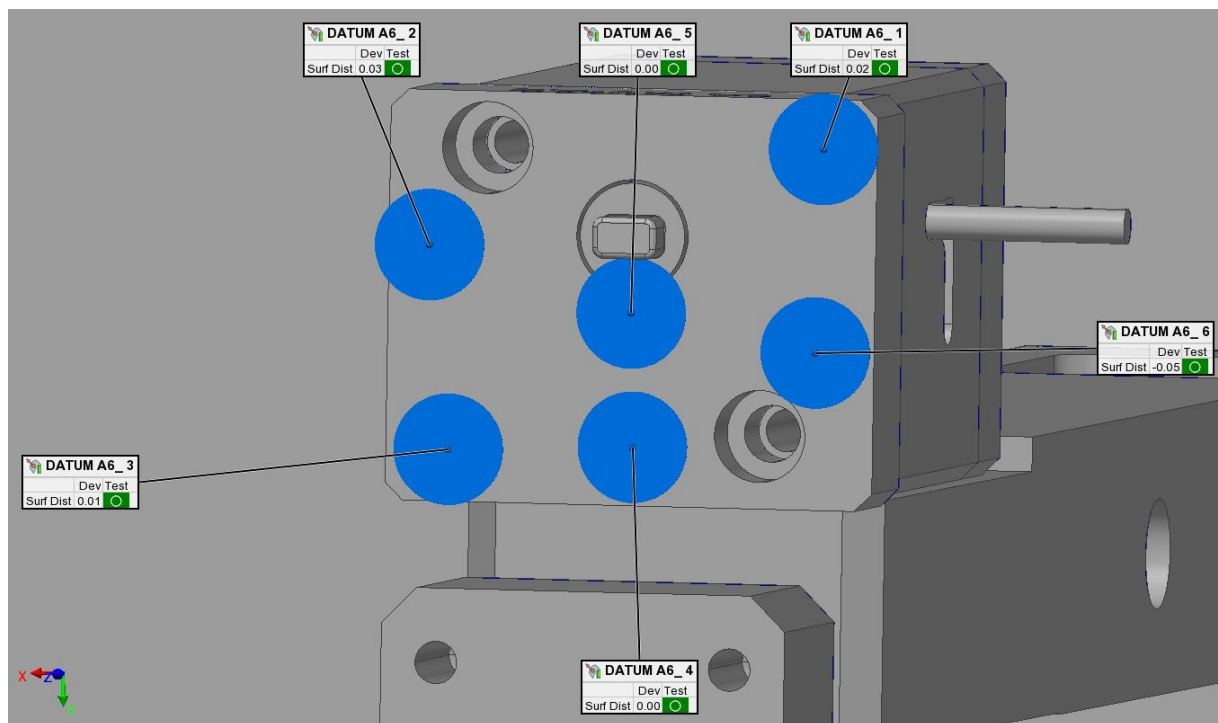

Comparison Point Table

Units Millimeters

DATUM A6_1

Control	Nom	Meas	Tol	Dev	Test
Surface Distance		0.02	±0.05	0.02	Pass

DATUM A6_2

Control	Nom	Meas	Tol	Dev	Test
Surface Distance		0.03	±0.05	0.03	Pass

DATUM A6_3

Control	Nom	Meas	Tol	Dev	Test
Surface Distance		0.01	±0.05	0.01	Pass

DATUM A6_4

Control	Nom	Meas	Tol	Dev	Test
Surface Distance		0.00	±0.05	0.00	Pass

DATUM A6_5

Control	Nom	Meas	Tol	Dev	Test
Surface Distance		0.00	±0.05	0.00	Pass

DATUM A6_6

Control	Nom	Meas	Tol	Dev	Test
Surface Distance		-0.05	±0.05	-0.05	Pass

Customer: MAGOVE
Operator: Felipe Martinez
E-mail: felipe.martinez@mess.com.mx

Part name: CC807-RH
Part number: 68228296/68228502
Piece: piece 1



Feature Table

Length Units Millimeters

▣ PIN A6

Control	Nom	Meas	Tol	Dev	Test
Length	5.80	5.80	+0.02/0.00	0.00	Pass
Width	3.70	3.70	+0.02/0.00	0.00	Pass
X	3336.44	3336.41	±0.10	-0.03	Pass
Y	590.45	590.42	±0.10	-0.03	Pass
Z	1826.33	1826.33	±0.10	0.00	Pass

Customer: MAGOVE

Operator: Felipe Martinez

E-mail: felipe.martinez@mess.com.mx

Part name: CC807-RH

Part number: 68228296/68228502

Piece: piece 1



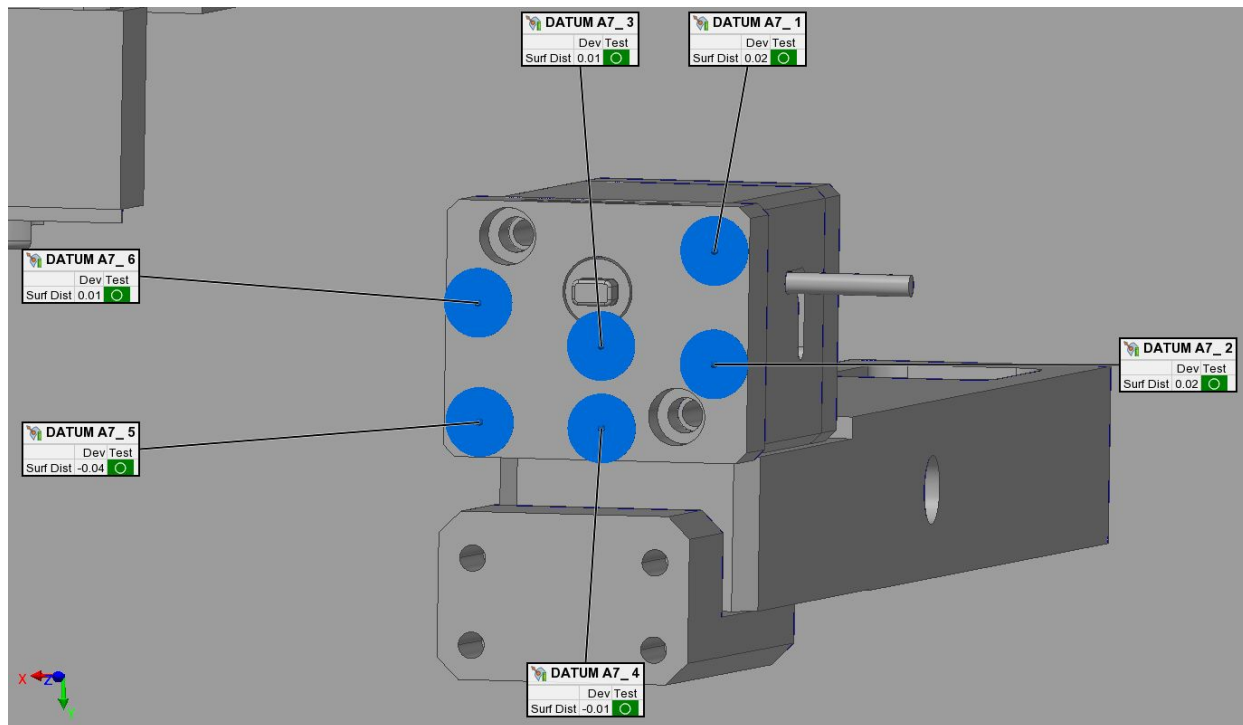

Comparison Point Table

Units Millimeters

DATUM A7_1

Control	Nom	Meas	Tol	Dev	Test
Surface Distance		0.02	±0.05	0.02	Pass

DATUM A7_2

Control	Nom	Meas	Tol	Dev	Test
Surface Distance		0.02	±0.05	0.02	Pass

DATUM A7_3

Control	Nom	Meas	Tol	Dev	Test
Surface Distance		0.01	±0.05	0.01	Pass

DATUM A7_4

Control	Nom	Meas	Tol	Dev	Test
Surface Distance		-0.01	±0.05	-0.01	Pass

DATUM A7_5

Control	Nom	Meas	Tol	Dev	Test
Surface Distance		-0.04	±0.05	-0.04	Pass

DATUM A7_6

Control	Nom	Meas	Tol	Dev	Test
Surface Distance		0.01	±0.05	0.01	Pass

Customer: MAGOVE
Operator: Felipe Martinez
E-mail: felipe.martinez@mess.com.mx

Part name: CC807-RH
Part number: 68228296/68228502
Piece: piece 1



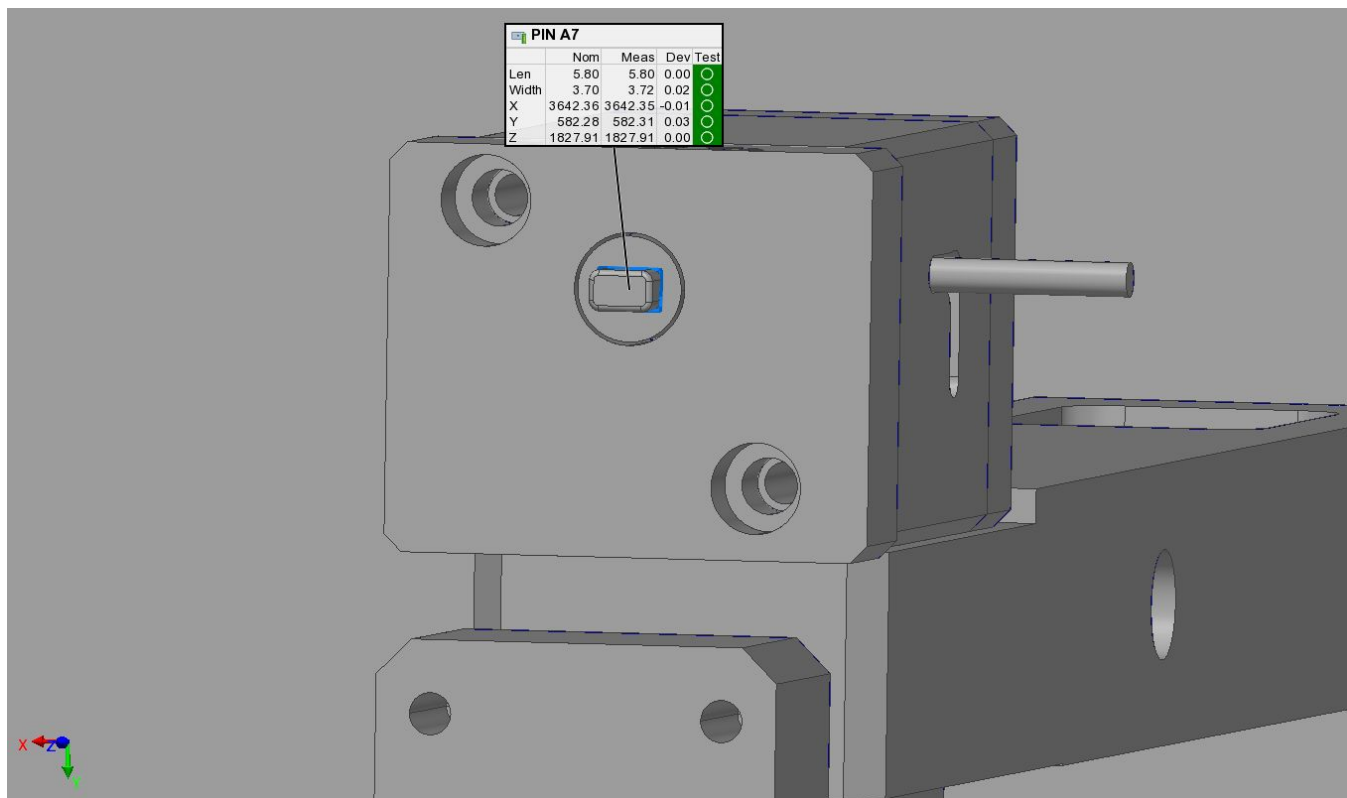

Feature Table

Length Units Millimeters

PIN A7

Control	Nom	Meas	Tol	Dev	Test
Length	5.80	5.80	+0.02/0.00	0.00	Pass
Width	3.70	3.72	+0.02/0.00	0.02	Pass
X	3642.36	3642.35	±0.10	-0.01	Pass
Y	582.28	582.31	±0.10	0.03	Pass
Z	1827.91	1827.91	±0.10	0.00	Pass

Customer: MAGOVE
Operator: Felipe Martinez
E-mail: felipe.martinez@mess.com.mx

Part name: CC807-RH
Part number: 68228296/68228502
Piece: piece 1



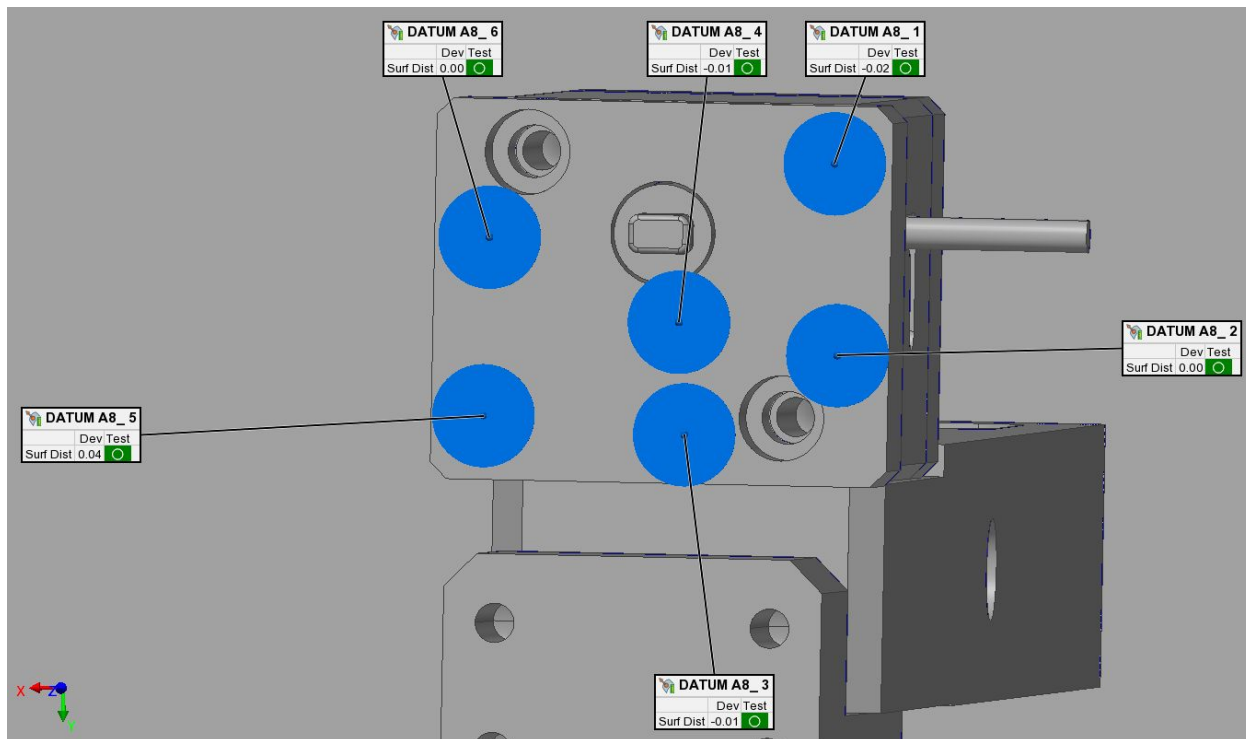

Comparison Point Table

Units Millimeters

DATUM A8_1

Control	Nom	Meas	Tol	Dev	Test
Surface Distance		-0.02	±0.05	-0.02	Pass

DATUM A8_2

Control	Nom	Meas	Tol	Dev	Test
Surface Distance		0.00	±0.05	0.00	Pass

DATUM A8_3

Control	Nom	Meas	Tol	Dev	Test
Surface Distance		-0.01	±0.05	-0.01	Pass

DATUM A8_4

Control	Nom	Meas	Tol	Dev	Test
Surface Distance		-0.01	±0.05	-0.01	Pass

DATUM A8_5

Control	Nom	Meas	Tol	Dev	Test
Surface Distance		0.04	±0.05	0.04	Pass

DATUM A8_6

Control	Nom	Meas	Tol	Dev	Test
Surface Distance		0.00	±0.05	0.00	Pass

Customer: MAGOVE
Operator: Felipe Martinez
E-mail: felipe.martinez@mess.com.mx

Part name: CC807-RH
Part number: 68228296/68228502
Piece: piece 1



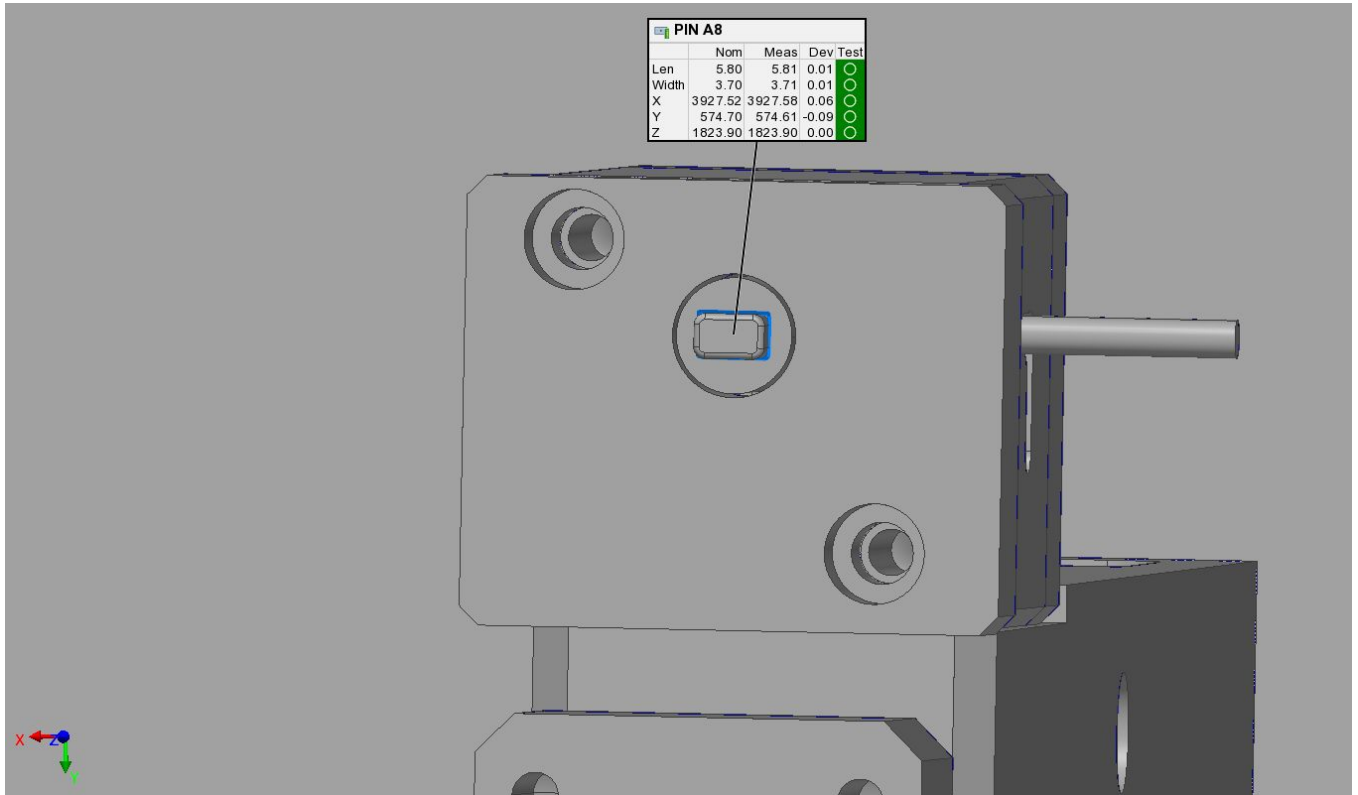

Feature Table

Length Units Millimeters

PIN A8

Control	Nom	Meas	Tol	Dev	Test
Length	5.80	5.81	+0.02/0.00	0.01	Pass
Width	3.70	3.71	+0.02/0.00	0.01	Pass
X	3927.52	3927.58	±0.10	0.06	Pass
Y	574.70	574.61	±0.10	-0.09	Pass
Z	1823.90	1823.90	±0.10	0.00	Pass

Customer: MAGOVE
Operator: Felipe Martinez
E-mail: felipe.martinez@mess.com.mx

Part name: CC807-RH
Part number: 68228296/68228502
Piece: piece 1



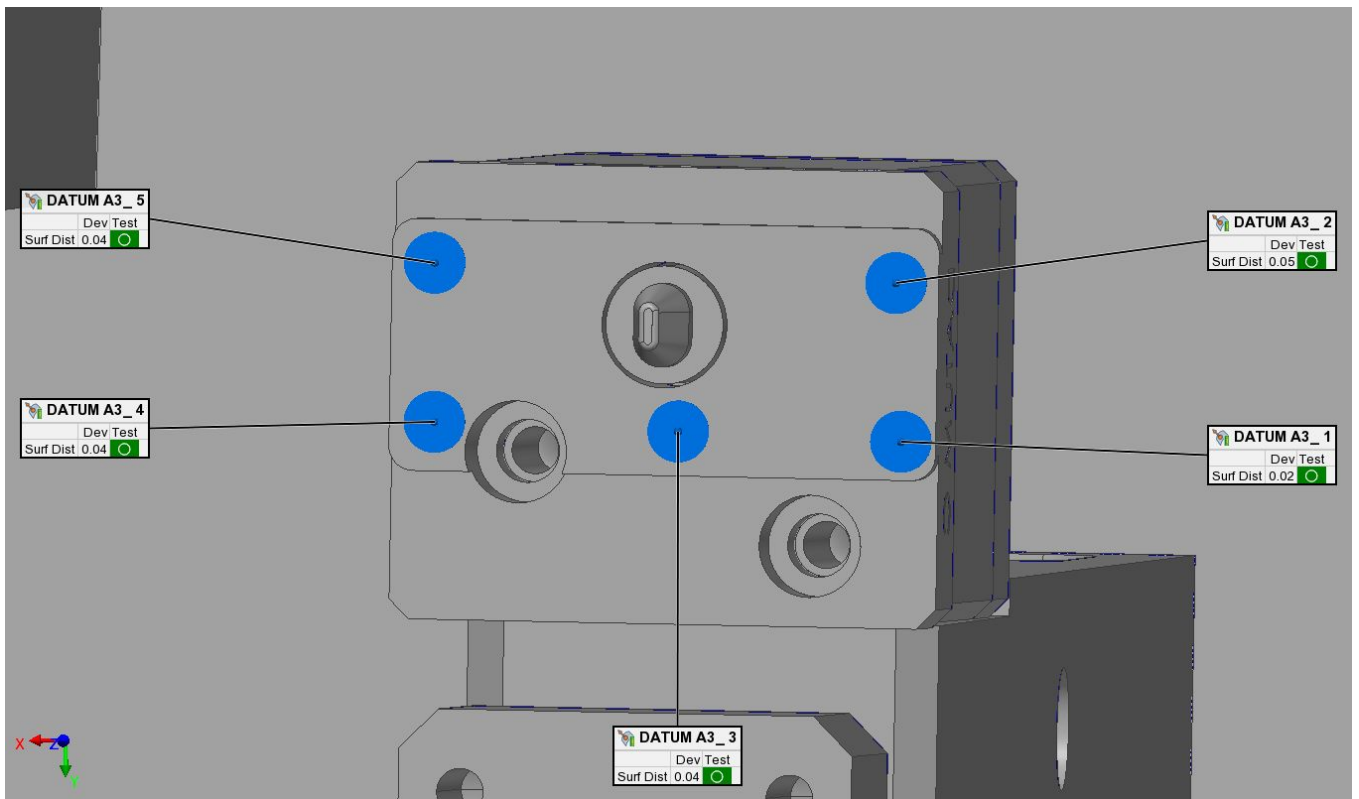

Comparison Point Table

Units Millimeters

DATUM A3_1

Control	Nom	Meas	Tol	Dev	Test
Surface Distance		0.02	±0.05	0.02	Pass

DATUM A3_2

Control	Nom	Meas	Tol	Dev	Test
Surface Distance		0.05	±0.05	0.05	Pass

DATUM A3_3

Control	Nom	Meas	Tol	Dev	Test
Surface Distance		0.04	±0.05	0.04	Pass

DATUM A3_4

Control	Nom	Meas	Tol	Dev	Test
Surface Distance		0.04	±0.05	0.04	Pass

DATUM A3_5

Control	Nom	Meas	Tol	Dev	Test
Surface Distance		0.04	±0.05	0.04	Pass

Customer: MAGOVE
Operator: Felipe Martinez
E-mail: felipe.martinez@mess.com.mx

Part name: CC807-RH
Part number: 68228296/68228502
Piece: piece 1



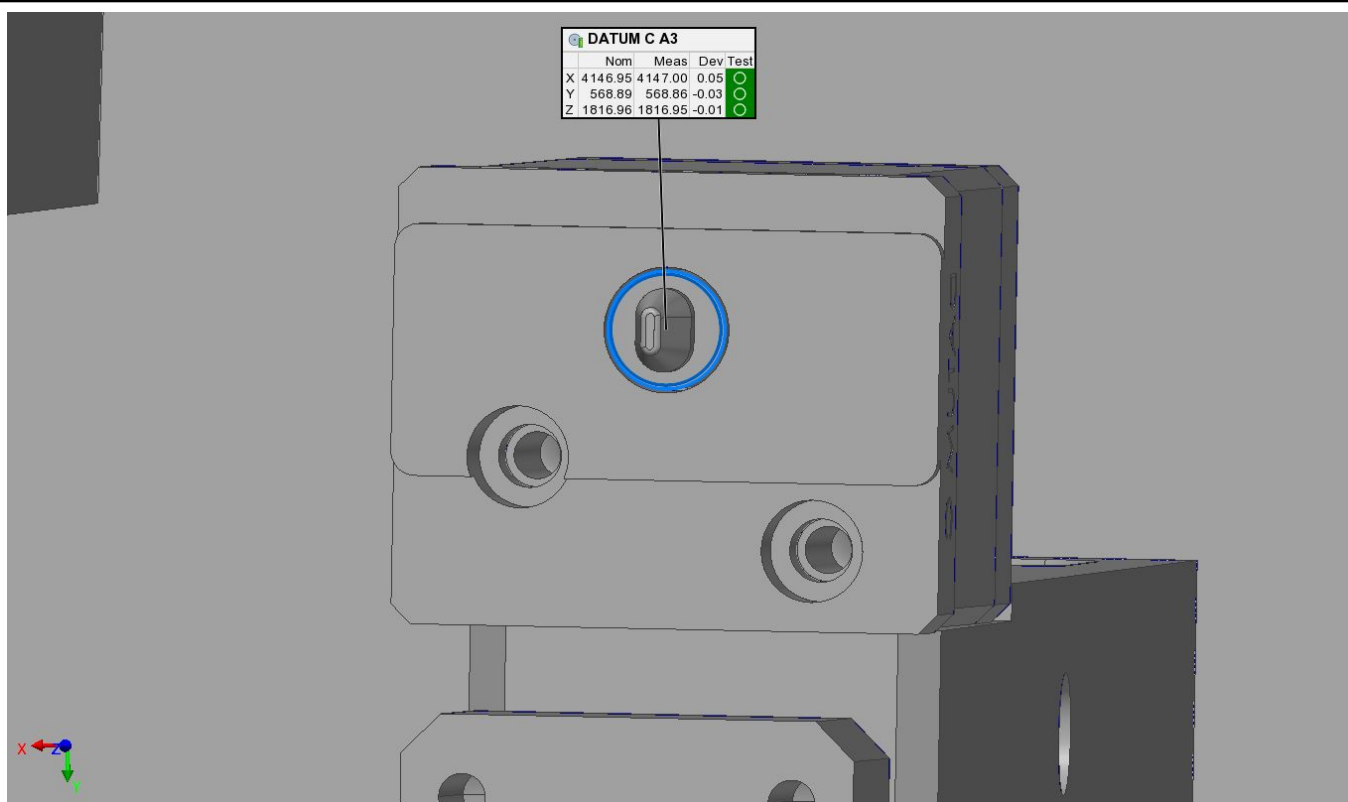

Feature Table

Length Units Millimeters

● DATUM C A3

Control	Nom	Meas	Tol	Dev	Test
X	4146.95	4147.00	±0.05	0.05	Pass
Y	568.89	568.86	±0.05	-0.03	Pass
Z	1816.96	1816.95	±0.05	-0.01	Pass

Customer: MAGOVE
Operator: Felipe Martinez
E-mail: felipe.martinez@mess.com.mx

Part name: CC807-RH
Part number: 68228296/68228502
Piece: piece 1



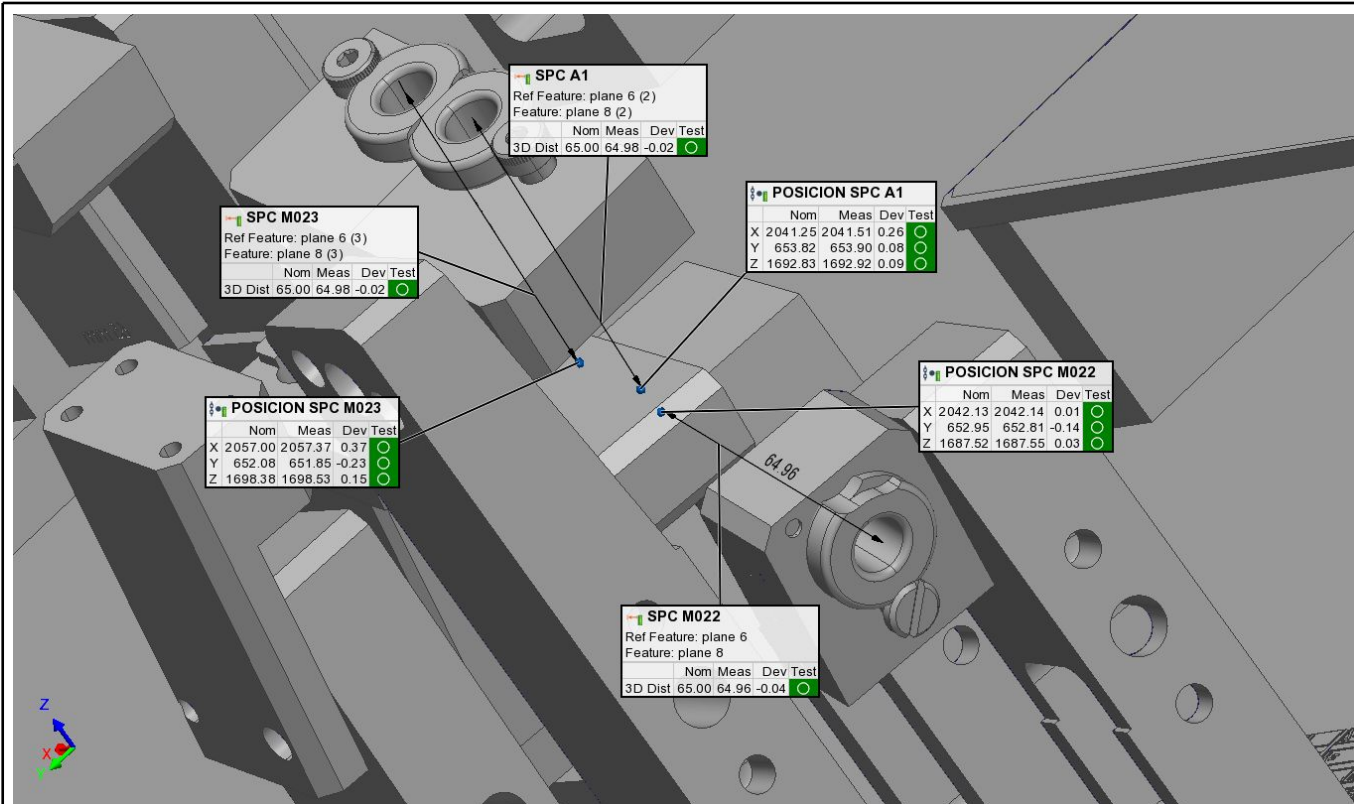

Feature Table

Length Units Millimeters

SPC M022

Feature: plane 8, Ref Feature: plane 6

Control	Nom	Meas	Tol	Dev	Test
3D Distance	65.00	64.96	±0.05	-0.04	Pass

• POSICION SPC M022

Control	Nom	Meas	Tol	Dev	Test
X	2042.13	2042.14	±0.50	0.01	Pass
Y	652.95	652.81	±0.50	-0.14	Pass
Z	1687.52	1687.55	±0.50	0.03	Pass

SPC A1

Feature: plane 8 (2), Ref Feature: plane 6 (2)

Control	Nom	Meas	Tol	Dev	Test
3D Distance	65.00	64.98	±0.05	-0.02	Pass

• POSICION SPC A1

Control	Nom	Meas	Tol	Dev	Test
X	2041.25	2041.51	±0.50	0.26	Pass
Y	653.82	653.90	±0.50	0.08	Pass
Z	1692.83	1692.92	±0.50	0.09	Pass

Customer: MAGOVE
Operator: Felipe Martinez
E-mail: felipe.martinez@mess.com.mx

Part name: CC807-RH
Part number: 68228296/68228502
Piece: piece 1



↔ SPC M023

Feature: plane 8 (3), Ref Feature: plane 6 (3)

Control	Nom	Meas	Tol	Dev	Test
3D Distance	65.00	64.98	±0.05	-0.02	Pass

• POSICION SPC M023

Control	Nom	Meas	Tol	Dev	Test
X	2057.00	2057.37	±0.50	0.37	Pass
Y	652.08	651.85	±0.50	-0.23	Pass
Z	1698.38	1698.53	±0.50	0.15	Pass

Customer: MAGOVE
Operator: Felipe Martinez
E-mail: felipe.martinez@mess.com.mx

Part name: CC807-RH
Part number: 68228296/68228502
Piece: piece 1



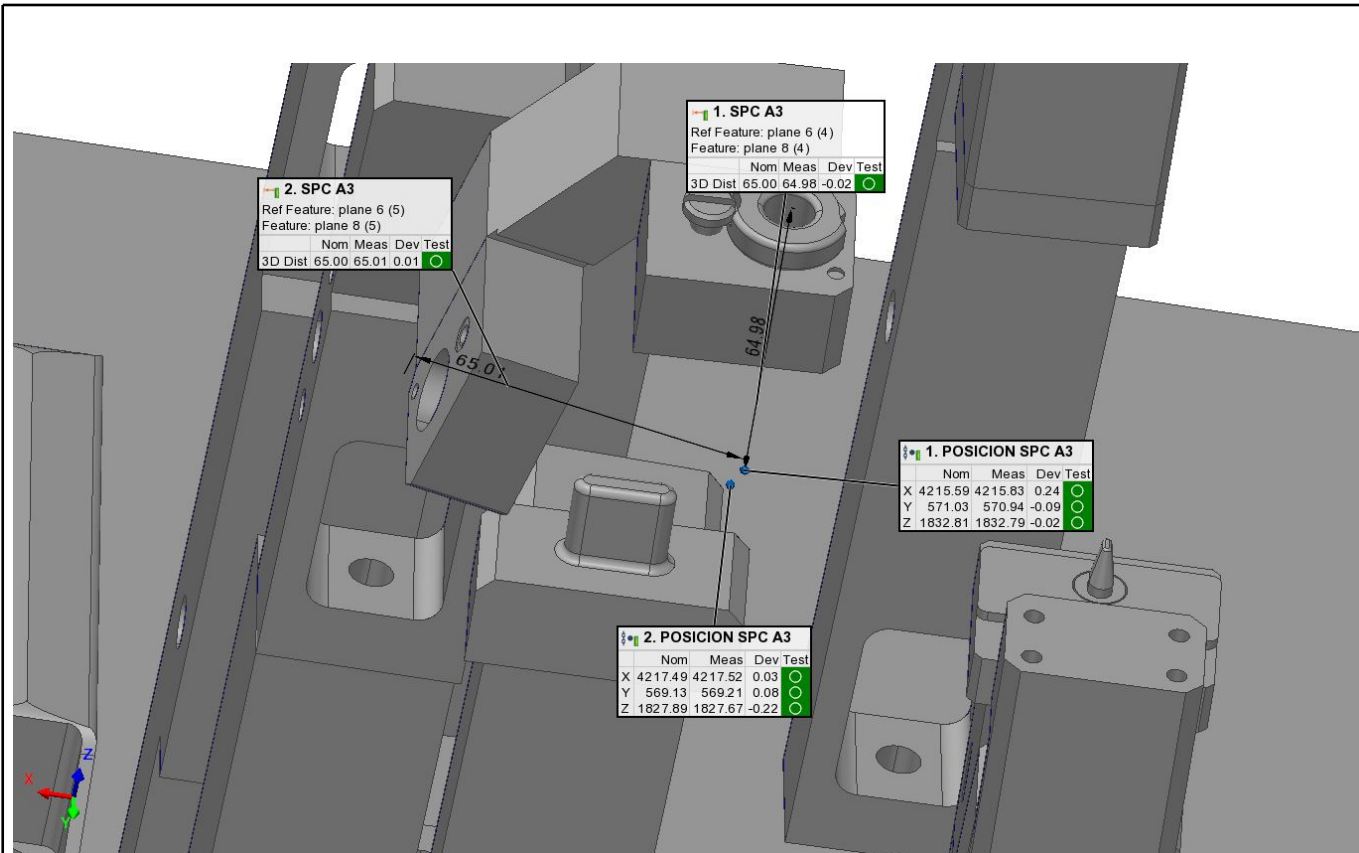

Feature Table

Length Units Millimeters

1. SPC A3 Feature: plane 8 (4), Ref Feature: plane 6 (4)

Control	Nom	Meas	Tol	Dev	Test
3D Distance	65.00	64.98	±0.05	-0.02	Pass

1. POSICION SPC A3

Control	Nom	Meas	Tol	Dev	Test
X	4215.59	4215.83	±0.50	0.24	Pass
Y	571.03	570.94	±0.50	-0.09	Pass
Z	1832.81	1832.79	±0.50	-0.02	Pass

2. SPC A3 Feature: plane 8 (5), Ref Feature: plane 6 (5)

Control	Nom	Meas	Tol	Dev	Test
3D Distance	65.00	65.01	±0.05	0.01	Pass

2. POSICION SPC A3

Control	Nom	Meas	Tol	Dev	Test
X	4217.49	4217.52	±0.50	0.03	Pass
Y	569.13	569.21	±0.50	0.08	Pass
Z	1827.89	1827.67	±0.50	-0.22	Pass

Customer: MAGOVE
Operator: Felipe Martinez
E-mail: felipe.martinez@mess.com.mx

Part name: CC807-RH
Part number: 68228296/68228502
Piece: piece 1



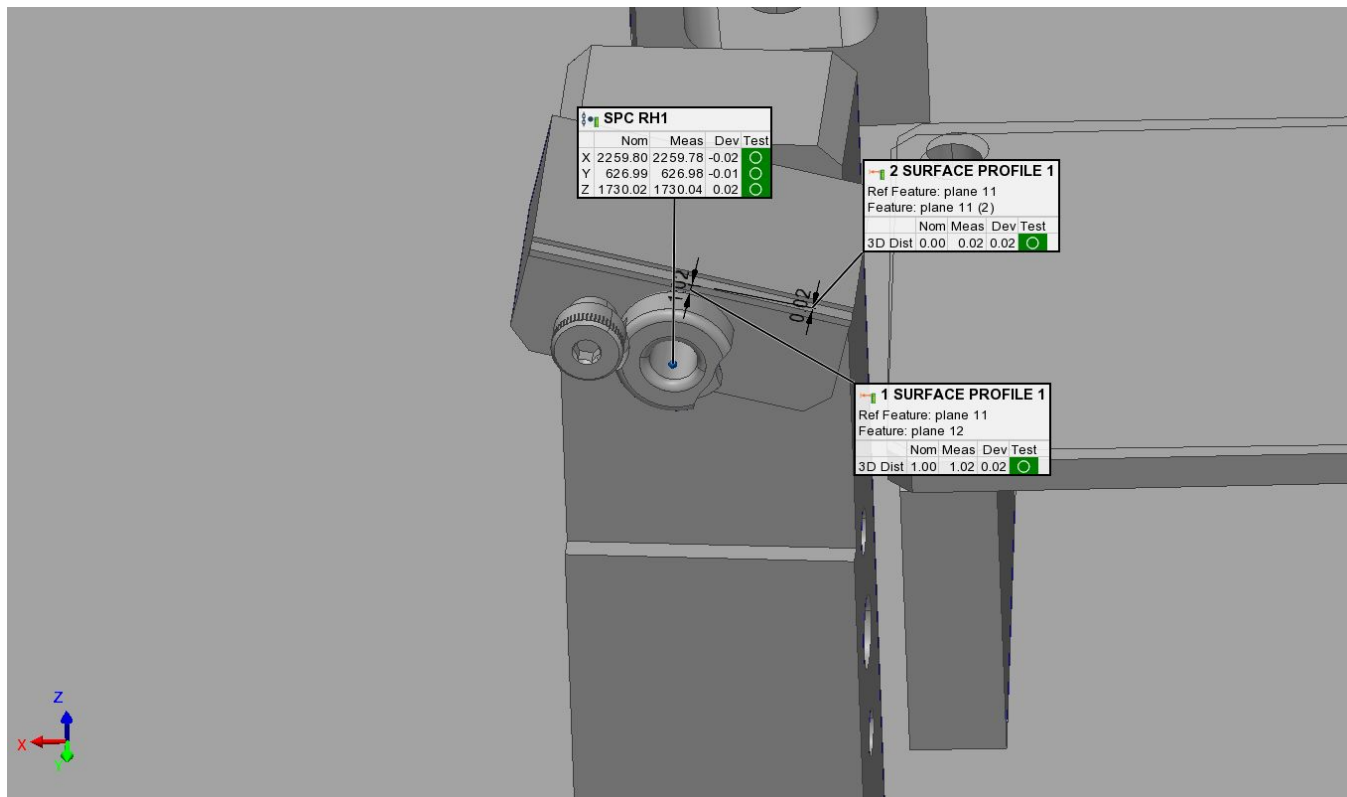

Feature Table

Length Units Millimeters

• SPC RH1

Control	Nom	Meas	Tol	Dev	Test
X	2259.80	2259.78	±0.05	-0.02	Pass
Y	626.99	626.98	±0.05	-0.01	Pass
Z	1730.02	1730.04	±0.05	0.02	Pass

↔ 1 SURFACE PROFILE 1

Feature: plane 12, Ref Feature: plane 11

Control	Nom	Meas	Tol	Dev	Test
3D Distance	1.00	1.02	+0.02/0.00	0.02	Pass

↔ 2 SURFACE PROFILE 1

Feature: plane 11 (2), Ref Feature: plane 11

Control	Nom	Meas	Tol	Dev	Test
3D Distance	0.00	0.02	±0.05	0.02	Pass

Customer: MAGOVE
Operator: Felipe Martinez
E-mail: felipe.martinez@mess.com.mx

Part name: CC807-RH
Part number: 68228296/68228502
Piece: piece 1



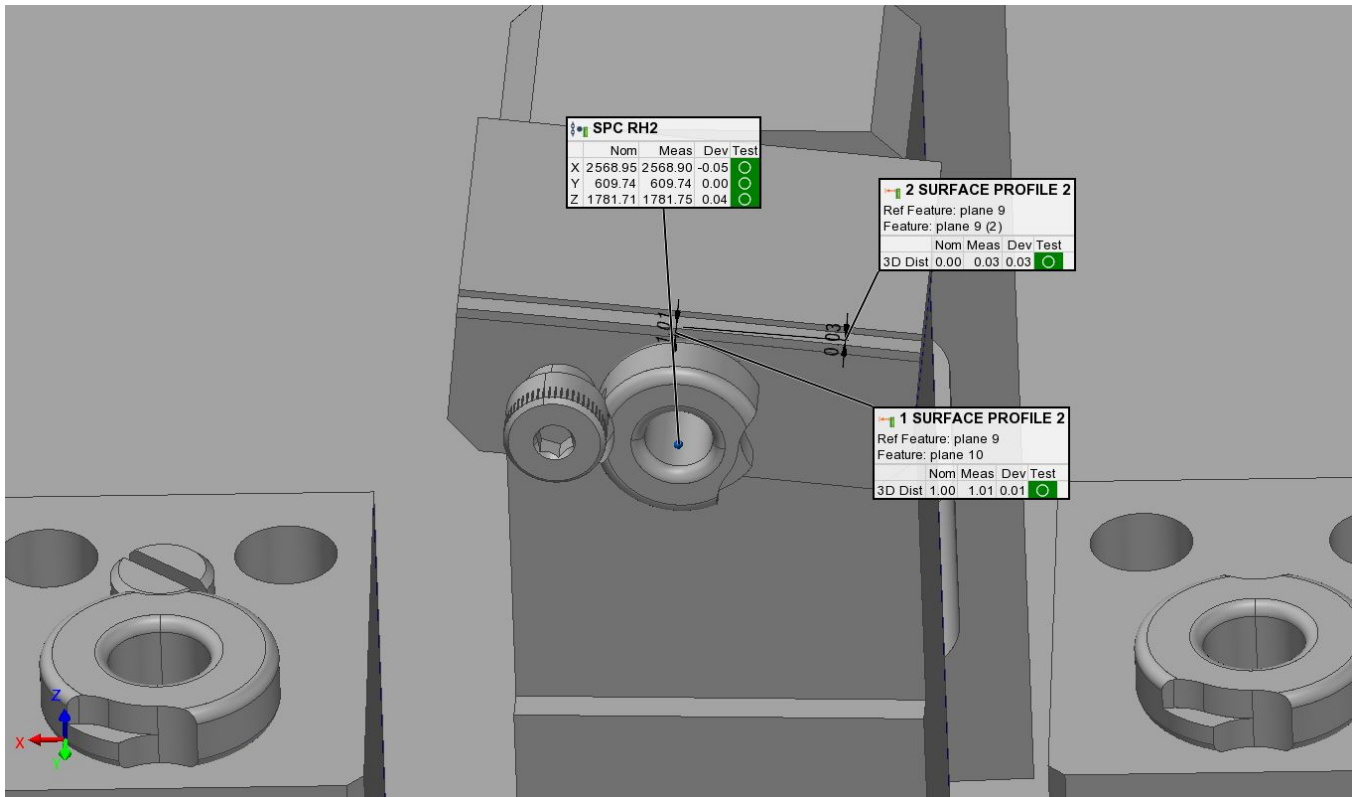

Feature Table

Length Units Millimeters

• SPC RH2

Control	Nom	Meas	Tol	Dev	Test
X	2568.95	2568.90	±0.05	-0.05	Pass
Y	609.74	609.74	±0.05	0.00	Pass
Z	1781.71	1781.75	±0.05	0.04	Pass

↔ 1 SURFACE PROFILE 2 Feature: plane 10, Ref Feature: plane 9

Control	Nom	Meas	Tol	Dev	Test
3D Distance	1.00	1.01	+0.02/0.00	0.01	Pass

↔ 2 SURFACE PROFILE 2 Feature: plane 9 (2), Ref Feature: plane 9

Control	Nom	Meas	Tol	Dev	Test
3D Distance	0.00	0.03	±0.05	0.03	Pass

Customer: MAGOVE
Operator: Felipe Martinez
E-mail: felipe.martinez@mess.com.mx

Part name: CC807-RH
Part number: 68228296/68228502
Piece: piece 1



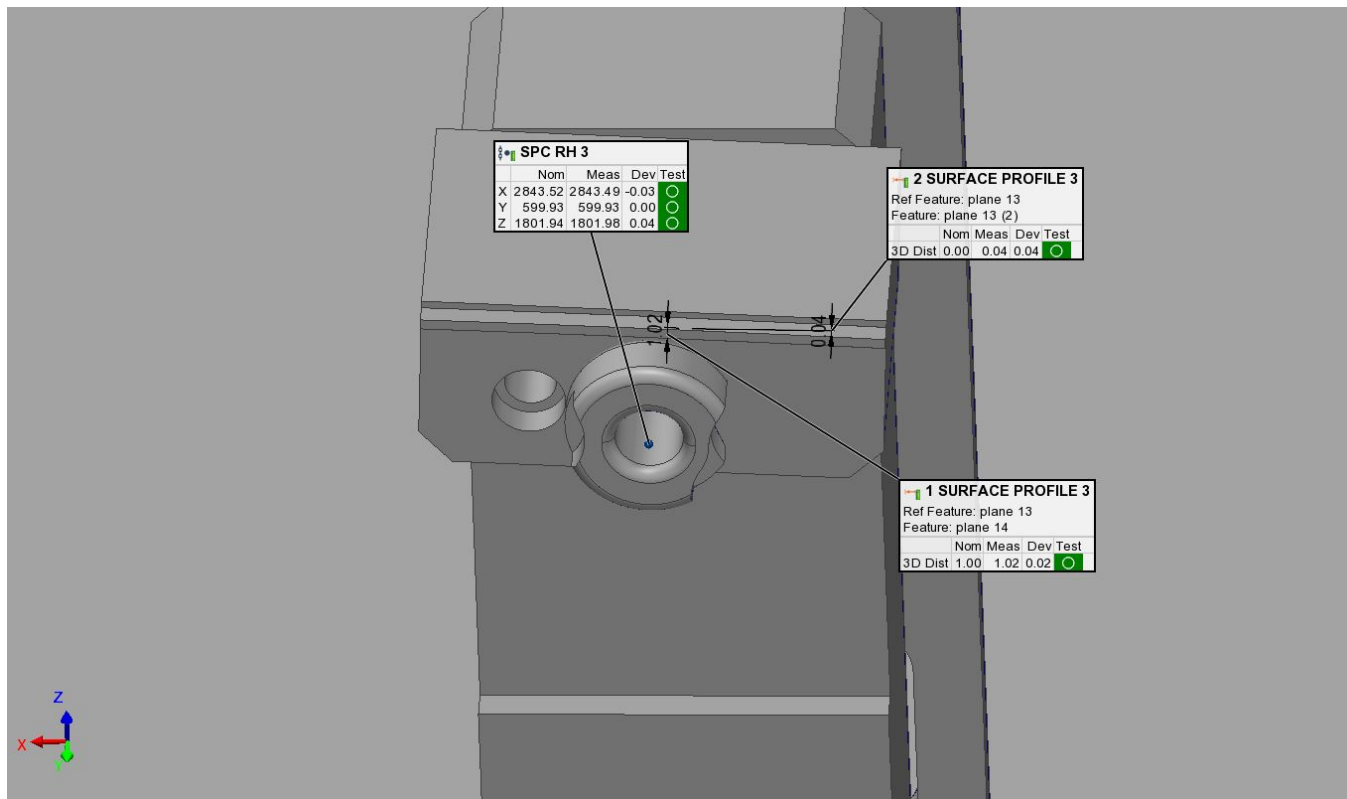

Feature Table

Length Units Millimeters

• SPC RH 3

Control	Nom	Meas	Tol	Dev	Test
X	2843.52	2843.49	±0.05	-0.03	Pass
Y	599.93	599.93	±0.05	0.00	Pass
Z	1801.94	1801.98	±0.05	0.04	Pass

↔ 1 SURFACE PROFILE 3

Feature: plane 14, Ref Feature: plane 13

Control	Nom	Meas	Tol	Dev	Test
3D Distance	1.00	1.02	+0.02/0.00	0.02	Pass

↔ 2 SURFACE PROFILE 3

Feature: plane 13 (2), Ref Feature: plane 13

Control	Nom	Meas	Tol	Dev	Test
3D Distance	0.00	0.04	±0.05	0.04	Pass

Customer: MAGOVE
Operator: Felipe Martinez
E-mail: felipe.martinez@mess.com.mx

Part name: CC807-RH
Part number: 68228296/68228502
Piece: piece 1



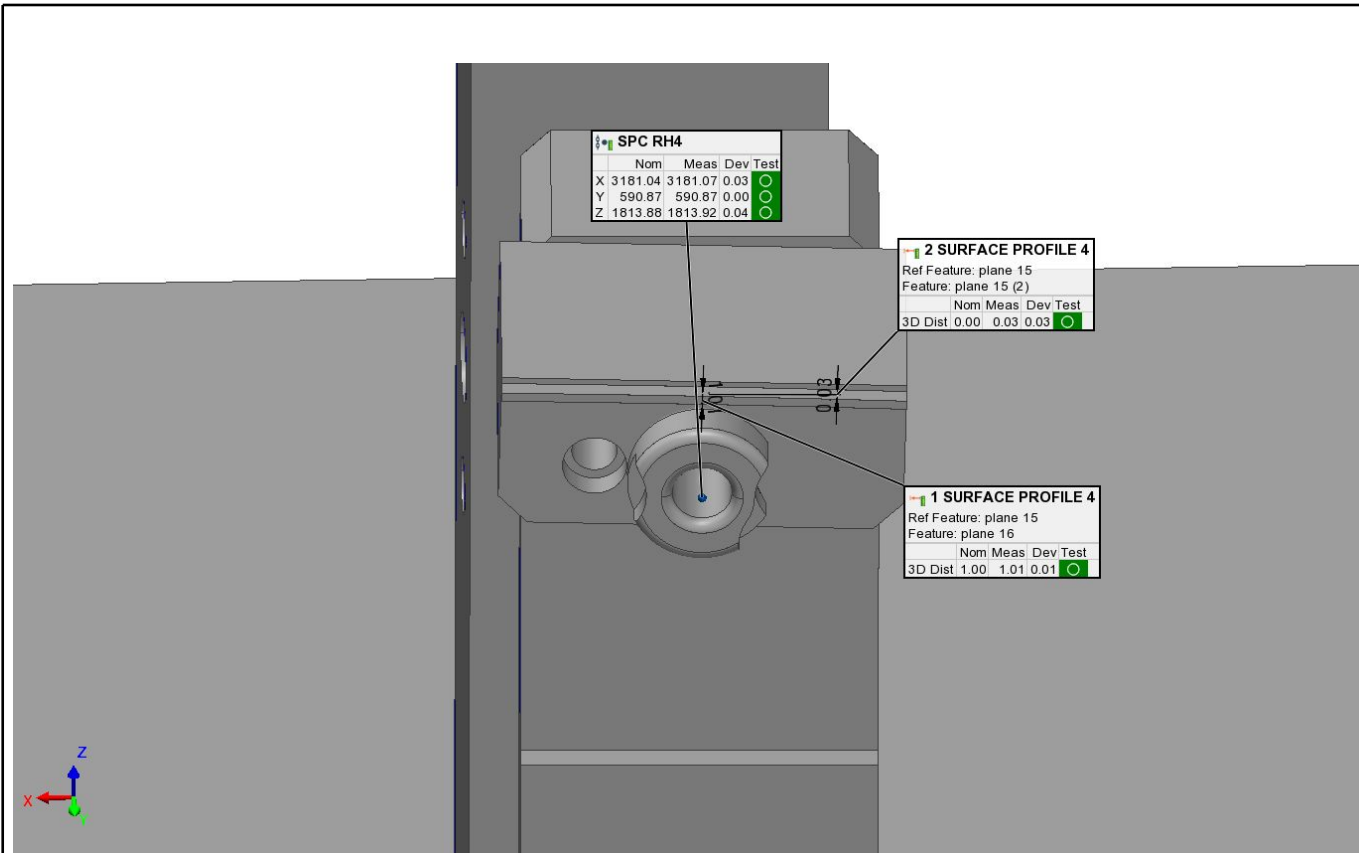

Feature Table

Length Units Millimeters

• SPC RH4

Control	Nom	Meas	Tol	Dev	Test
X	3181.04	3181.07	±0.05	0.03	Pass
Y	590.87	590.87	±0.05	0.00	Pass
Z	1813.88	1813.92	±0.05	0.04	Pass

↔ 1 SURFACE PROFILE 4

Feature: plane 16, Ref Feature: plane 15

Control	Nom	Meas	Tol	Dev	Test
3D Distance	1.00	1.01	+0.02/0.00	0.01	Pass

↔ 2 SURFACE PROFILE 4

Feature: plane 15 (2), Ref Feature: plane 15

Control	Nom	Meas	Tol	Dev	Test
3D Distance	0.00	0.03	±0.05	0.03	Pass

Customer: MAGOVE
Operator: Felipe Martinez
E-mail: felipe.martinez@mess.com.mx

Part name: CC807-RH
Part number: 68228296/68228502
Piece: piece 1



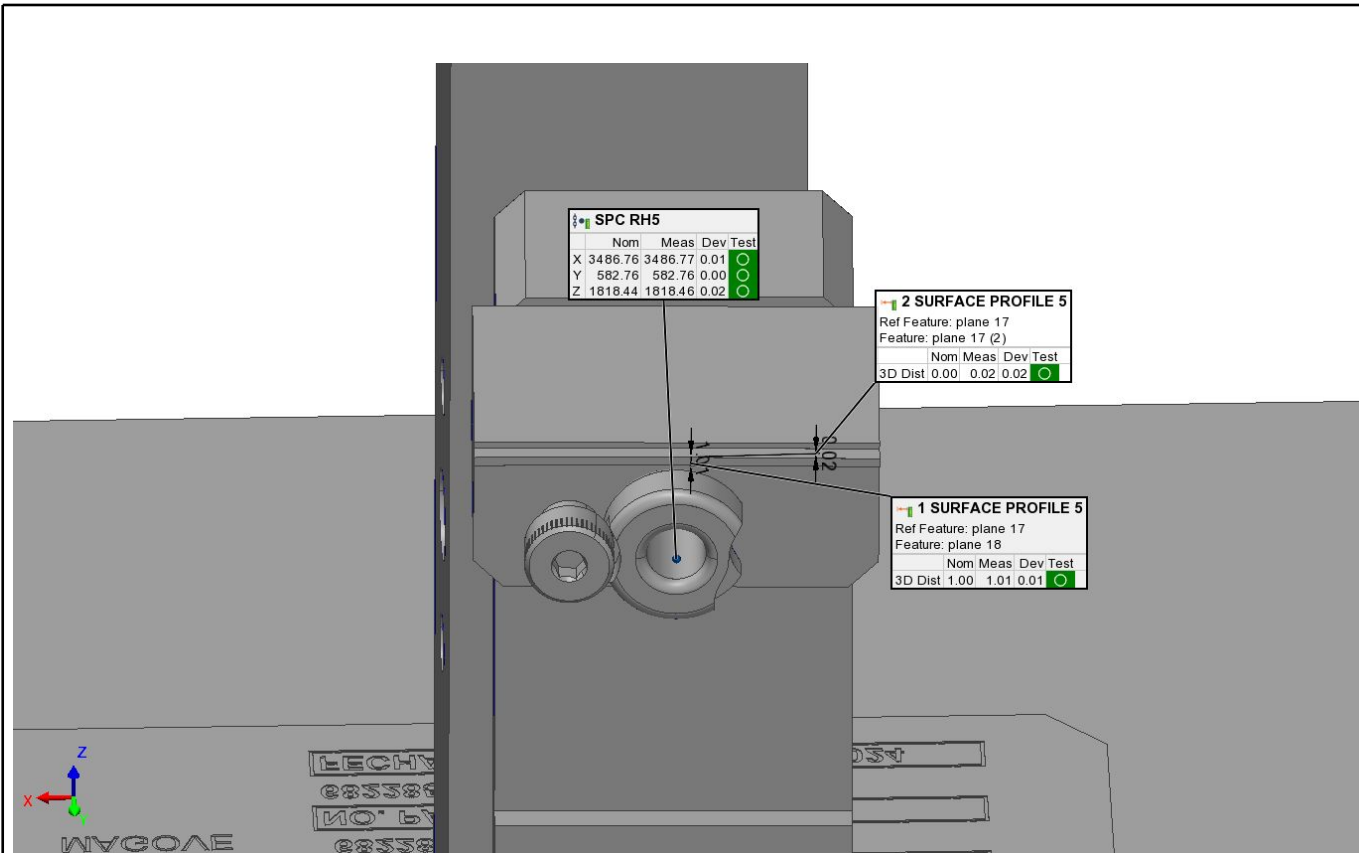

Feature Table

Length Units Millimeters

• SPC RH5

Control	Nom	Meas	Tol	Dev	Test
X	3486.76	3486.77	±0.05	0.01	Pass
Y	582.76	582.76	±0.05	0.00	Pass
Z	1818.44	1818.46	±0.05	0.02	Pass

↔ 1 SURFACE PROFILE 5

Feature: plane 18, Ref Feature: plane 17

Control	Nom	Meas	Tol	Dev	Test
3D Distance	1.00	1.01	+0.02/0.00	0.01	Pass

↔ 2 SURFACE PROFILE 5

Feature: plane 17 (2), Ref Feature: plane 17

Control	Nom	Meas	Tol	Dev	Test
3D Distance	0.00	0.02	±0.05	0.02	Pass

Customer: MAGOVE
Operator: Felipe Martinez
E-mail: felipe.martinez@mess.com.mx

Part name: CC807-RH
Part number: 68228296/68228502
Piece: piece 1



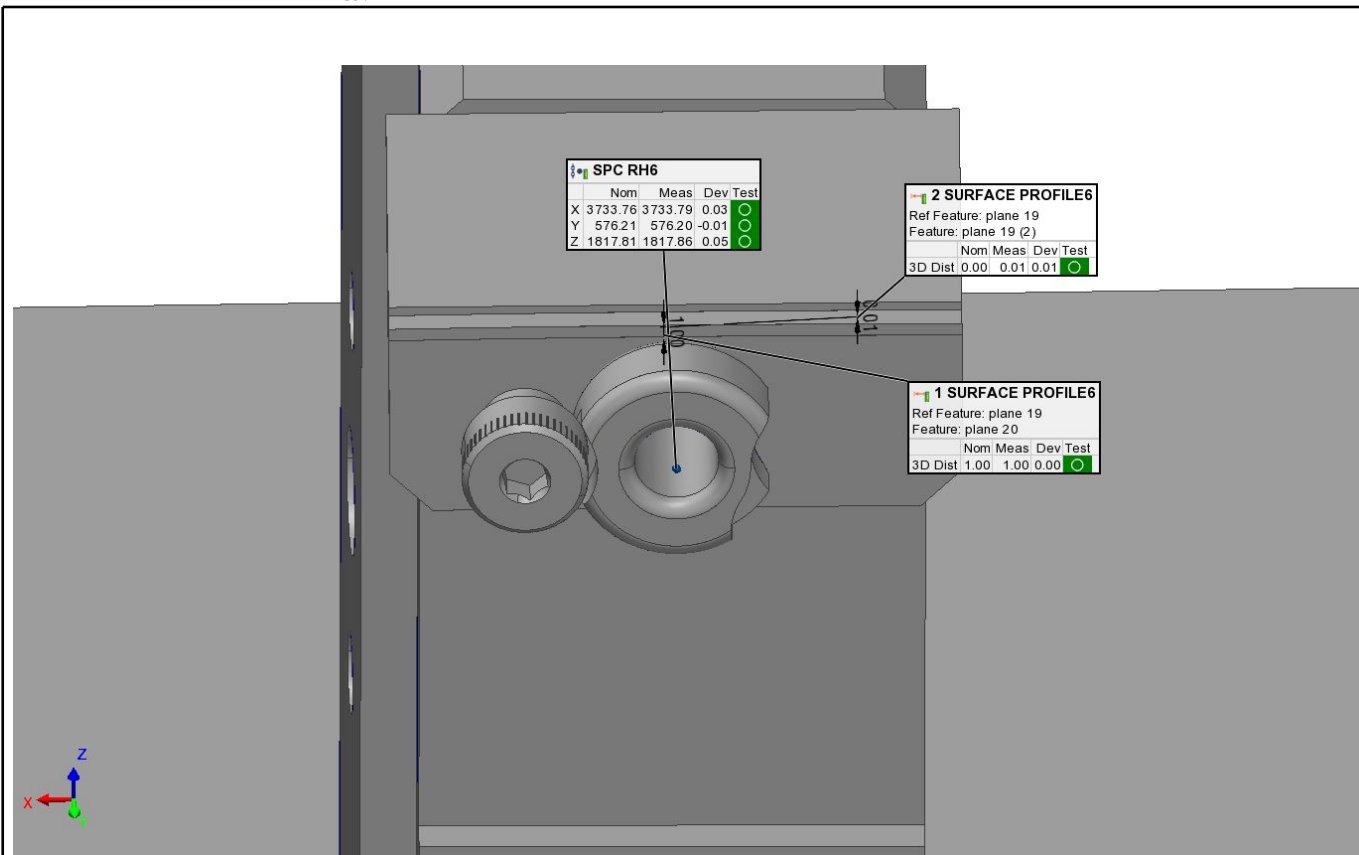

Feature Table

Length Units Millimeters

• SPC RH6

Control	Nom	Meas	Tol	Dev	Test
X	3733.76	3733.79	±0.05	0.03	Pass
Y	576.21	576.20	±0.05	-0.01	Pass
Z	1817.81	1817.86	±0.05	0.05	Pass

↔ 1 SURFACE PROFILE6

Feature: plane 20, Ref Feature: plane 19

Control	Nom	Meas	Tol	Dev	Test
3D Distance	1.00	1.00	+0.02/0.00	0.00	Pass

↔ 2 SURFACE PROFILE6

Feature: plane 19 (2), Ref Feature: plane 19

Control	Nom	Meas	Tol	Dev	Test
3D Distance	0.00	0.01	±0.05	0.01	Pass

Customer: MAGOVE
Operator: Felipe Martinez
E-mail: felipe.martinez@mess.com.mx

Part name: CC807-RH
Part number: 68228296/68228502
Piece: piece 1



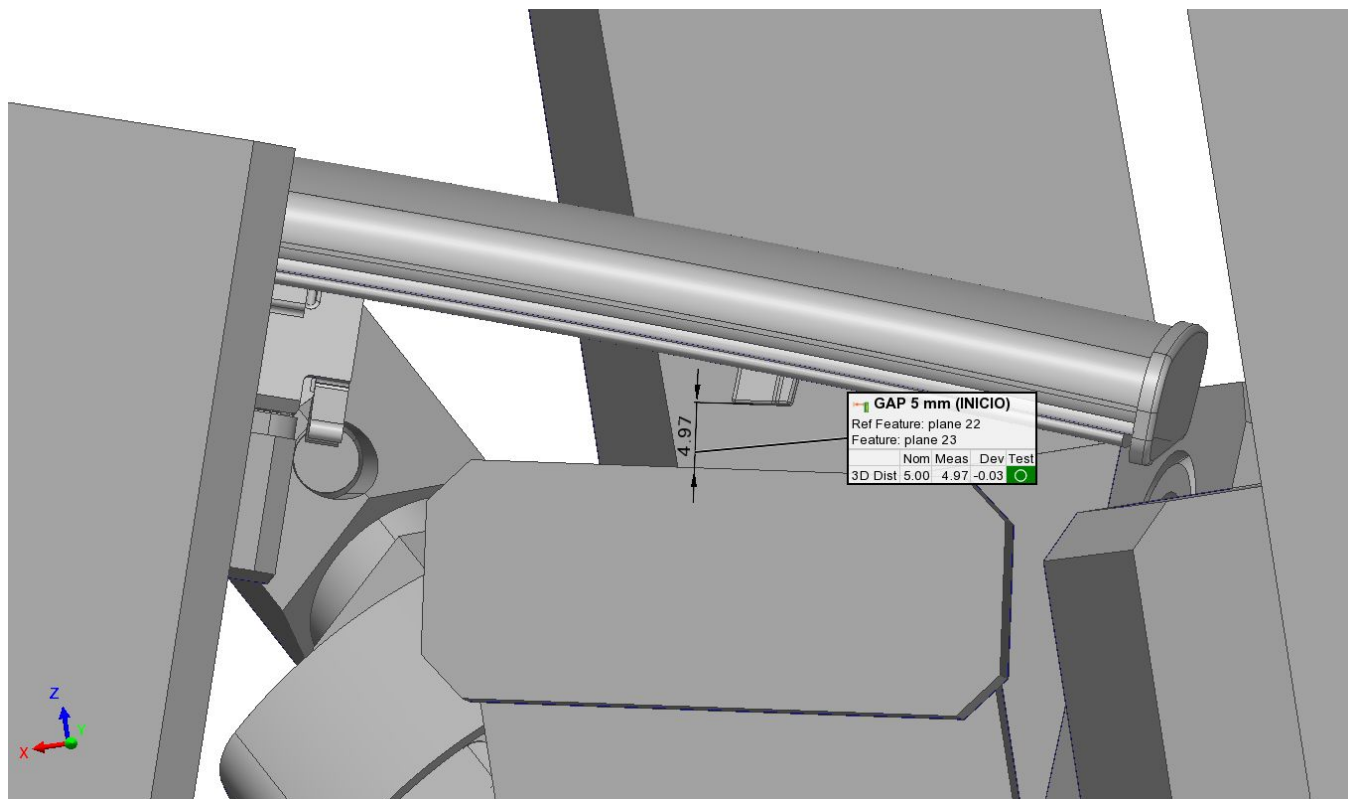

Feature Table

Length Units Millimeters

↔ GAP 5 mm (INICIO)

Feature: plane 23, Ref Feature: plane 22

Control	Nom	Meas	Tol	Dev	Test
3D Distance	5.00	4.97	±0.05	-0.03	Pass

Customer: MAGOVE
Operator: Felipe Martinez
E-mail: felipe.martinez@mess.com.mx

Part name: CC807-RH
Part number: 68228296/68228502
Piece: piece 1



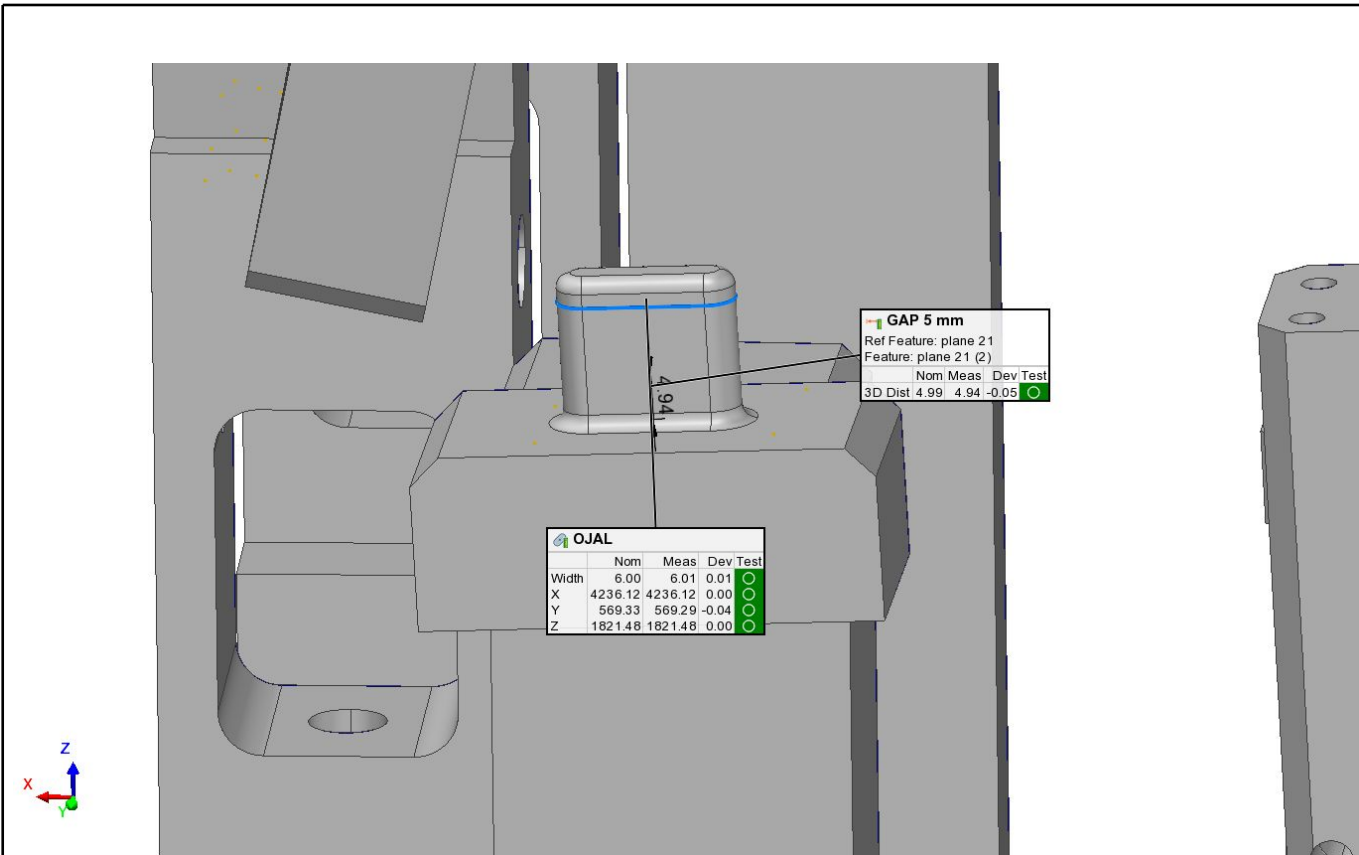

Feature Table

Length Units Millimeters

OJAL

Control	Nom	Meas	Tol	Dev	Test
Width	6.00	6.01	+0.02/0.00	0.01	Pass
X	4236.12	4236.12	±0.10	0.00	Pass
Y	569.33	569.29	±0.10	-0.04	Pass
Z	1821.48	1821.48	±0.10	0.00	Pass

GAP 5 mm

Feature: plane 21 (2), Ref Feature: plane 21

Control	Nom	Meas	Tol	Dev	Test
3D Distance	4.99	4.94	±0.05	-0.05	Pass

Customer: MAGOVE
Operator: Felipe Martinez
E-mail: felipe.martinez@mess.com.mx

Part name: CC807-RH
Part number: 68228296/68228502
Piece: piece 1



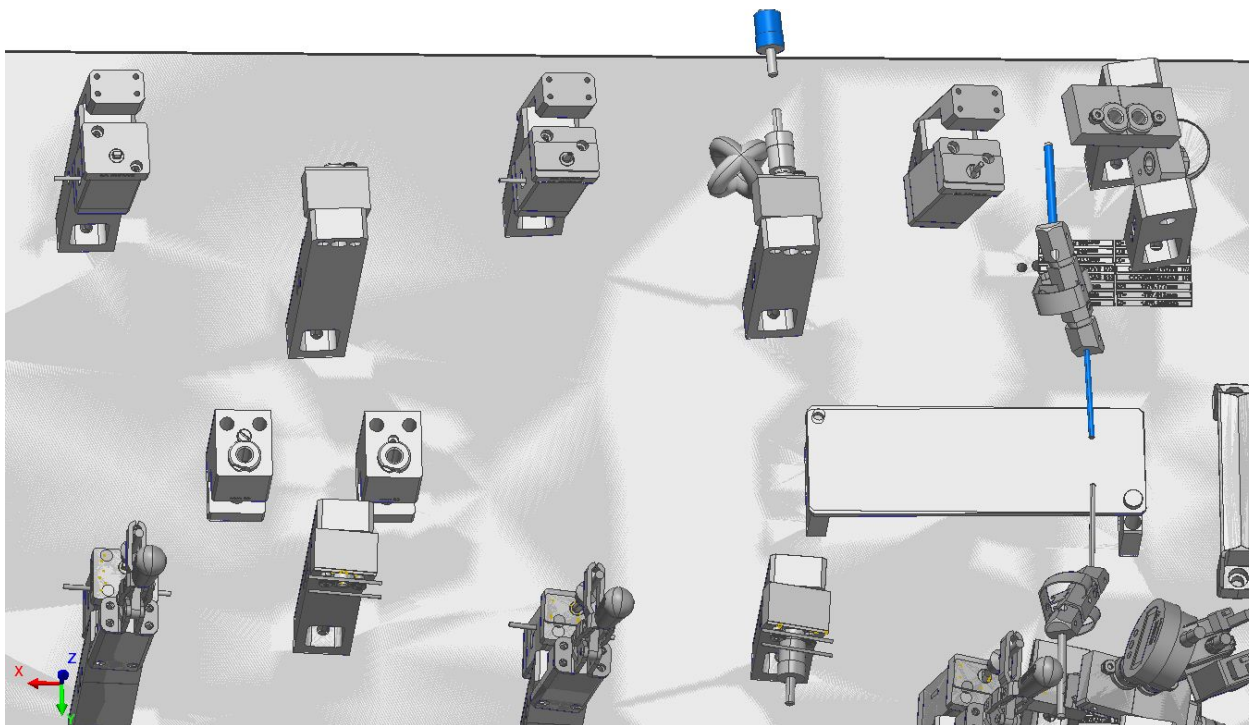

Feature Table

Length Units Millimeters

NO GO FEELER

Control	Nom	Meas	Tol	Dev	Test
Diameter	6.00	6.00	0.00/-0.02	0.00	Pass

GO FEELER

Control	Nom	Meas	Tol	Dev	Test
Diameter	4.00	4.01	+0.02/0.00	0.01	Pass

GO FEELER MARCA VISUAL

Control	Nom	Meas	Tol	Dev	Test
Diameter	18.00	18.00	+0.02/0.00	0.00	Pass

NO GO FEELER MARCA VISUAL

Control	Nom	Meas	Tol	Dev	Test
Diameter	19.00	19.00	0.00/-0.02	0.00	Pass

MASTER RELOJ PUNTA

Feature: plane 28, Ref Feature: plane 5

Control	Nom	Meas	Tol	Dev	Test
3D Distance	65.00	65.00	±0.05	0.00	Pass

MASTER RELOJ ESFERA

Feature: sphere 1, Ref Feature: plane 29

Control	Nom	Meas	Tol	Dev	Test
3D Distance	65.00	64.99	±0.05	-0.01	Pass

Customer: MAGOVE
Operator: Felipe Martinez
E-mail: felipe.martinez@mess.com.mx

Part name: CC807-RH
Part number: 68228296/68228502
Piece: piece 1

