

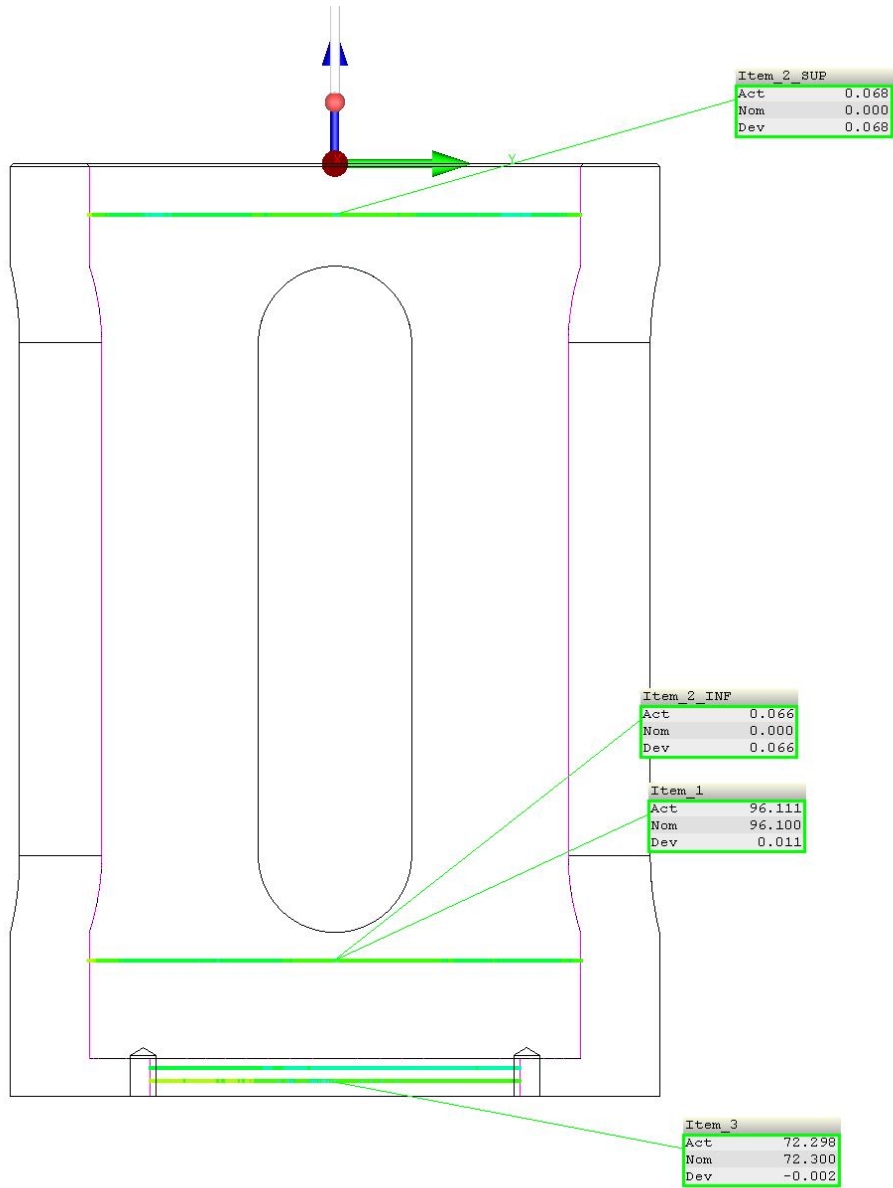

Plan Name TSL1021 gauge concentricidad	Run All Characteristics	Process sheet le * vda_auditno
Date of the last program modification 2025-03-13	Version	Order * order *
Last program modification TSL1021	Incremental Part Number 1	Temperature workpiece



20 mm



Name	ID	Actual	Nominal	pos Tol	neg Tol	Diff	<-- -->
Item_1	D	96.111	96.100	0.050	-0.050	0.011	-
Item_2_INF	Con	0.066	0.000	0.080		0.066	----
Item_2_SUP	Con	0.068	0.000	0.080		0.068	----
Item_3	D	72.298	72.300	0.050	-0.050	-0.002	-

